



# Sealed SKF Explorer spherical roller bearings

Optimum protection against contaminants,  
downtime and high maintenance costs





# Seal profits into every bearing arrangement

## One choice. Every advantage.

Productivity. Maintenance costs. Environmental issues. Your choice of bearings has a direct effect on all of these challenges, and ultimately, on your bottom line. SKF makes that choice easy, with a bearing that delivers an optimal solution – for virtually any application.

Sealed SKF Explorer spherical roller bearings are designed to keep lubricant in and contaminants out of the bearing. The three main benefits of this feature are:

- **Significantly reduced need for maintenance**
- **Minimized grease consumption and environmental impact**
- **Substantially increased uptime**

As a single component that solves multiple challenges, it just doesn't make sense to use anything else.

## Protects against contaminants

Sealed SKF Explorer spherical roller bearings are pre-lubricated with a high-quality bearing grease and sealed with high-performance contact seals. The seals protect the bearing and lubricant from contaminants that might otherwise cause premature bearing failure.

## Substantially reduces the need for relubrication

In many applications, sealed SKF Explorer spherical roller bearings can be considered lubricated for the life of the bearing. By eliminating or extending relubrication intervals, the cost to purchase and dispose of lubricant can be reduced. Reducing maintenance costs can in some cases, substantially reduce the total cost of ownership of an application.

## Suitable for oil-bath applications

While sealed spherical roller bearings are normally grease lubricated, they can also be used in applications where the oil bath method is used. In these applications, the seal acts as a filter to keep contaminants in the oil from entering the bearing cavity. This filtering action increases the service life of both the bearing and the lubricant.

## All the benefits of an open bearing – sealed in

Sealed SKF Explorer spherical roller bearings are designed for applications where there are high demands on cleanliness or high levels of contamination, heavy radial loads, and misalignment due primarily to shaft deflections.



**Bottom line benefits**

Benefits of sealed SKF Explorer spherical roller bearings include:

- Increased uptime
- Reduced need for maintenance
- Reduced grease consumption and disposal cost
- Environmentally friendly
- Longer bearing service life
- Eliminates the need for expensive relubrication systems
- Improved worker safety

## Widest assortment of sealed spherical roller bearings on the market

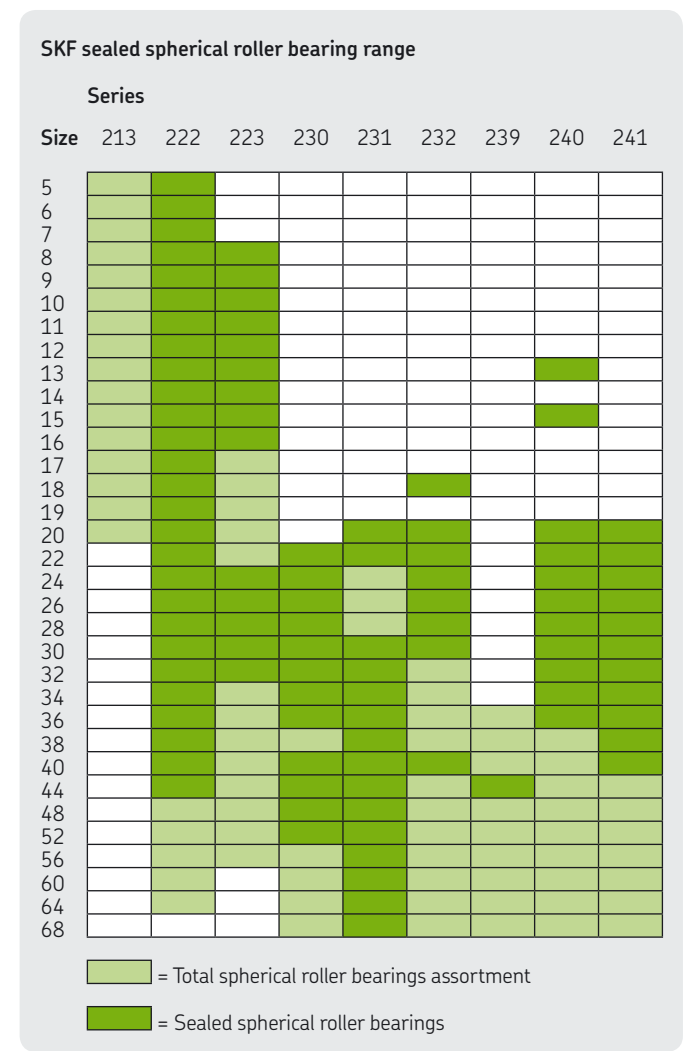



# Seal profits into every bearing arrangement

## One choice. Every advantage.

Productivity. Maintenance costs. Environmental issues. Your choice of bearings has a direct effect on all of these challenges, and ultimately, on your bottom line. SKF makes that choice easy, with a bearing that delivers an optimal solution – for virtually any application.

Sealed SKF Explorer spherical roller bearings are designed to keep lubricant in and contaminants out of the bearing. The three main benefits of this feature are:

- **Significantly reduced need for maintenance**
- **Minimized grease consumption and environmental impact**
- **Substantially increased uptime**

As a single component that solves multiple challenges, it just doesn't make sense to use anything else.

## Protects against contaminants

Sealed SKF Explorer spherical roller bearings are pre-lubricated with a high-quality bearing grease and sealed with high-performance contact seals. The seals protect the bearing and lubricant from contaminants that might otherwise cause premature bearing failure.

## Substantially reduces the need for relubrication

In many applications, sealed SKF Explorer spherical roller bearings can be considered lubricated for the life of the bearing. By eliminating or extending relubrication intervals, the cost to purchase and dispose of lubricant can be reduced. Reducing maintenance costs can in some cases, substantially reduce the total cost of ownership of an application.

## Suitable for oil-bath applications

While sealed spherical roller bearings are normally grease lubricated, they can also be used in applications where the oil bath method is used. In these applications, the seal acts as a filter to keep contaminants in the oil from entering the bearing cavity. This filtering action increases the service life of both the bearing and the lubricant.

## All the benefits of an open bearing – sealed in

Sealed SKF Explorer spherical roller bearings are designed for applications where there are high demands on cleanliness or high levels of contamination, heavy radial loads, and misalignment due primarily to shaft deflections.

## An environmentally responsible choice

In some industrial applications, the only way to fight the ingress of contaminants is by pumping large quantities of grease through the bearing with the goal of forcing contaminants out. With sealed SKF Explorer spherical roller bearings, contaminants are effectively prevented from entering the bearing. This reduces the need to purchase, pump and dispose of large quantities of grease.

## Ready to use, trouble-free to install

For applications where there are moderate levels of contamination, no additional grease or seals are necessary.

Sealed bearings are also trouble-free to install because contaminants, which could cause premature bearing failure, cannot enter into the bearing during mounting.

To increase bearing service life in highly contaminated environments, SKF recommends filling the housing with an environmentally friendly SKF grease and adding an external housing seal.

## Enables sizing-down

When compared to an open (unsealed) bearing, the higher cleanliness level inside a sealed spherical roller bearing makes it possible to size-down the bearing arrangement without negatively affecting the performance of the application.

## The SKF three-barrier solution

For harsh operating environments, SKF recommends the three barrier solution. This environmentally friendly, cost-effective bundle of products can extend bearing service life without complicated and expensive sealing arrangements. The effectiveness of the SKF three-barrier solution is in its simplicity. It protects the bearing during assembly and operation.

**1. SKF L-seals or S-seals** – These standard, cost-effective housing seals are characterized by their ability to prevent the ingress of contaminants.

**2. Housing grease** – SKF recommends filling the housing with SKF LGGB2 grease to act as a contamination barrier. This biodegradable, environmentally-friendly grease is an excellent alternative to filling the housing with bearing grease.

**3. Integral bearing seals** – These very effective seals keep the high quality bearing lubricant in and contaminants out of the bearing cavity.

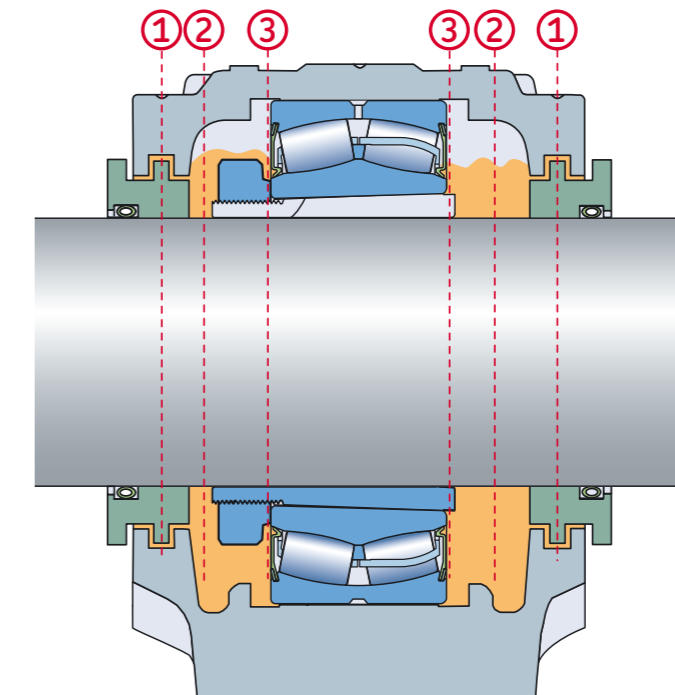
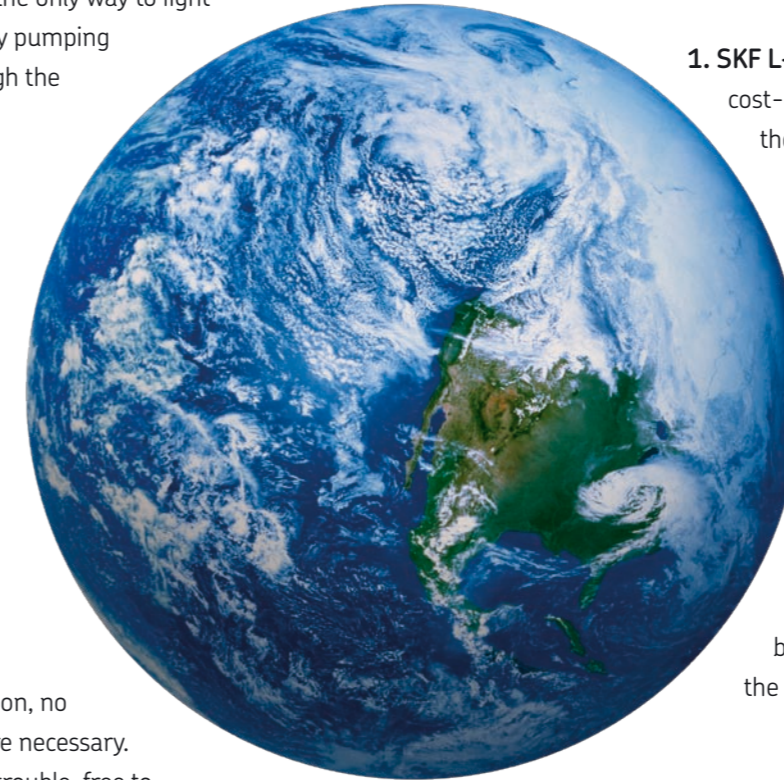

### Bottom line benefits

Benefits of sealed SKF Explorer spherical roller bearings include:

- Increased uptime
- Reduced need for maintenance
- Reduced grease consumption and disposal cost
- Environmentally friendly
- Longer bearing service life
- Eliminates the need for expensive relubrication systems
- Improved worker safety

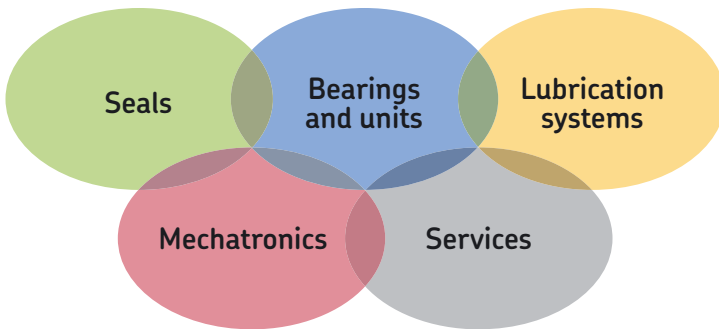

### The Power of Knowledge Engineering

Drawing on five areas of competence and application-specific expertise amassed over more than 100 years, SKF brings innovative solutions to OEMs and production facilities in every major industry worldwide. These five competence areas include bearings and units, seals, lubrication systems, mechatronics (combining mechanics and electronics into intelligent systems), and a wide range of services, from 3-D computer modelling to advanced condition monitoring and reliability and asset management services. A global presence provides SKF customers uniform quality standards and worldwide product availability.

<sup>TM</sup> SKF Explorer is a trademark of the SKF Group.

© SKF is a registered trademark of the SKF Group.

© SKF Group 2009

The contents of this publication are the copyright of the publisher and may not be reproduced (even extracts) unless prior written permission is granted. Every care has been taken to ensure the accuracy of the information contained in this publication but no liability can be accepted for any loss or damage whether direct, indirect or consequential arising out of the use of the information contained herein.

Publication **7053 EN** · June 2009

Printed in Sweden on environmentally friendly paper.

Certain image(s) used under license from Shutterstock.com.