



ERIKS Sealing Technology

Specialist Seals for Heavy Industrial Application



know-how makes the difference

ERIKS

“ **Large scale sealing solutions are conceived out of understanding, admiration and respect for the application.** ”

David McIntosh
Pioneer Weston 1964 - 2013

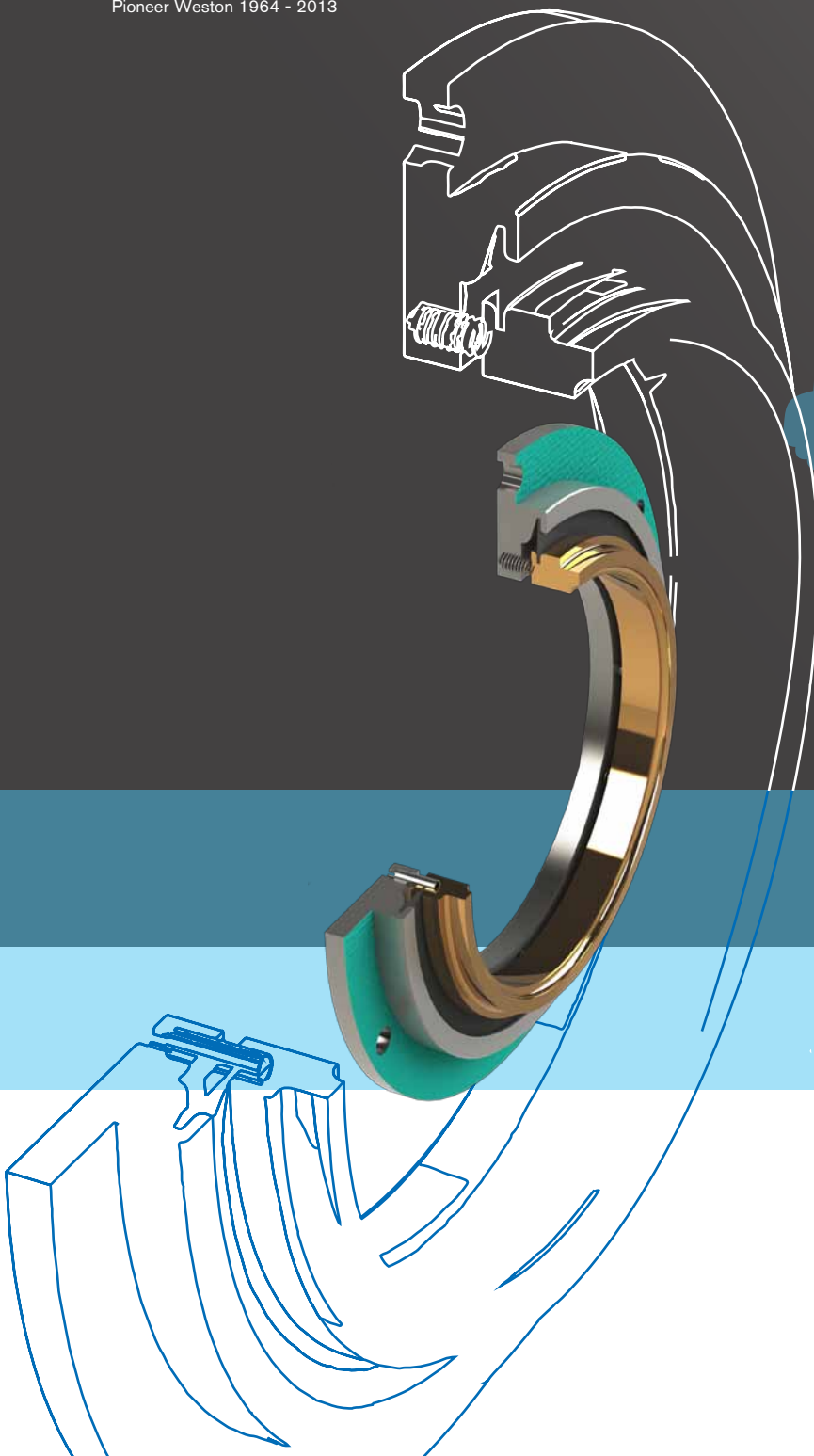

**Non Balanced Mechanical Seal
Type MRX**

Contents

CAPABILITIES	04
MATERIALS	08
Elastomers	08
Standard ERIKS Compounds	18
ERIKS Compounds Physical Properties	19
Chemical Compatibility Chart	20
APPLICATIONS	22
PRODUCTS	30
Heavy Duty Rotary Lip Seals	30
Elastomeric Lip Seals	31
Solid Body PTFE Seals	33
GS Split	36
Metal Face Seals	37
Weston Mechanical Seals	38
Balanced Mechanical Seal	39
Non Balanced Mechanical Seal	40
Face Type Seal	42
Vulc-O-ring	43
Spring Energised Seal	44
O-ring	46
Heavy Duty Hydraulic Seal Profiles	48
ADDITIONAL PRODUCTS & SERVICES	50
V-rings	50
Carbon Segment Seals	50
Lip Seals	51
Laminar Seals	51
Bellow Seals	52
Stationary Components	52
Taper Spring Seals	53
Parallel Spring Seals	53
Brochures in the Series	54
Kitting & Bagging	55

All information in this documentation has been compiled with care to ensure accuracy. Despite this we can bear no liability for error and/or changes in legislation that may affect content. Recommendations are intended as guidelines only, for further information and technical assistance, please consult your Applications Engineer.

Aflas is a trademark of Asahi Glass
 Stellite is a trademark of Deloro Stellite Company Inc.
 Freon, Viton, Teflon and Vamac are trademarks of Dupont.
 Elgiloy is a trademark of Elgiloy Ltd.
 Hastelloy is a trademark of Haynes International Inc.

© Copyright, intellectual and all other proprietary rights in the content (including but not limited to text and photographs) rests with ERIKS SEALING TECHNOLOGY (UK)

Leader in Sealing Technology

Pioneer Weston has a long history of innovative design enabling us to create a sealing device specific to our customer's needs.

Thermo-chemical and environmental conditions dictate material selection, whilst gland space, special features and sometimes sheer scale have to be considered before the best sealing solution can be identified. This is particularly true of Heavy Industrial Sealing Applications.

Large dimensions result in large tolerances and clearance gaps that, combined with pressure or force, may cause elevated stresses within the seal. The sheer scale of equipment often requires designs that allow in-situ servicing, with only partial disassembly, but also fabricated from differing materials that are better suited to such dimensions. Tailored designs are required to mitigate for such requirements.

ERIKS service many customers within Heavy Industry across all of our core activities, but our expertise in sealing shines through in the form of our Pioneer Weston range. Pioneer Weston's core product range consists of Elastomer and PTFE Rotary Lip Seals, along with bespoke Mechanical seals. Pioneer

Weston is a premium brand of ERIKS Sealing Technology, after more than 80 years Pioneer Weston remains at the forefront of sealing technology offering continued innovation in the sealing of heavy duty applications, from un-balanced mechanical sealing assemblies in Steel Mills to large diameter split elastomer seals in industrial fans.

Augmenting our Pioneer Weston range, ERIKS Sealing Technology has vast expertise in the specification and supply of polymer seals on a truly global basis.

These products are supported by advanced technical and logistics services that form the link between our know-how and your delivery.

The global ERIKS group of companies are product driven industrial service providers, focussing on five core activities:

- **Sealing technology**
- **Power transmission**
- **Flow technology**
- **Industrial plastics**
- **Tools and maintenance products**

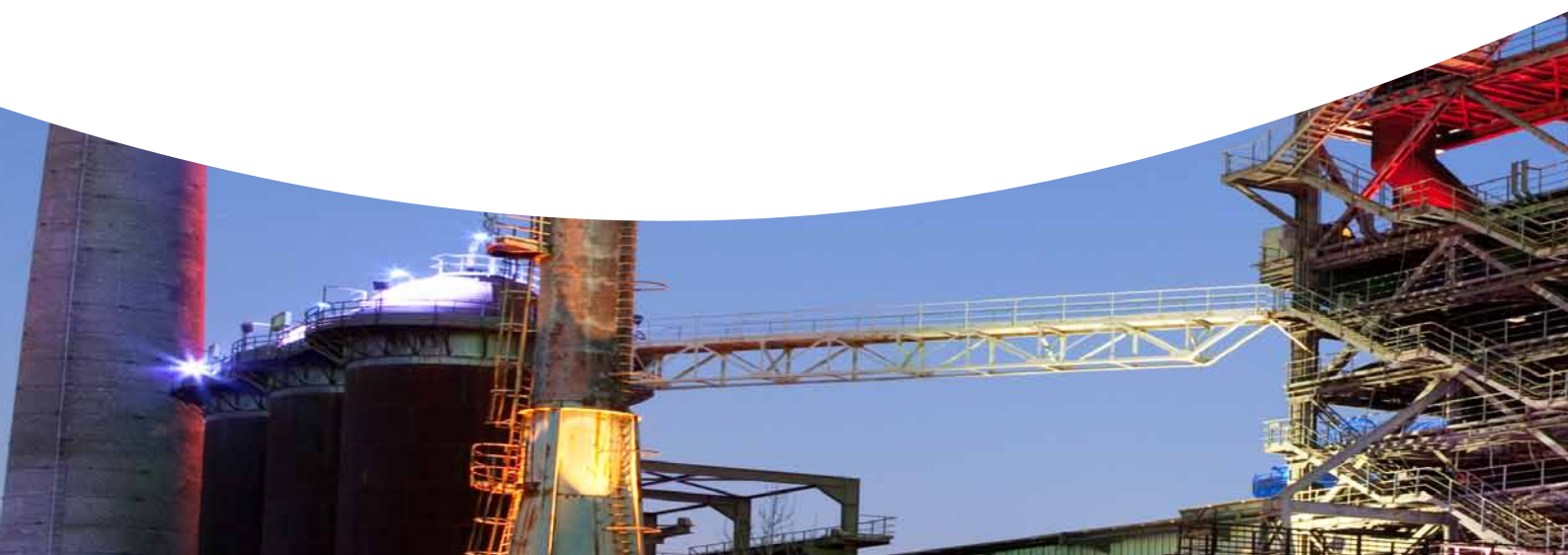



ERIKS Sealing Technology is a world leader in high-performance sealing systems. We hold ISO 9001:2008 certification across both of the UK sealing core competence centres and throughout our distribution network for your peace of mind.

Whether your requirement is for individual products, small batches or production volumes, ERIKS Sealing Technology's manufacturing, logistics and quality systems ensure delivery of the highest levels of service.

We are the preferred partner of the key global seal manufacturing companies, giving ERIKS an unrivalled insight into their capabilities and the resources available, allowing us to add value to your business and the products that you produce by selecting the optimal technical and logistical solution for your application.

Stock Availability

As one of the worlds largest stockholders of sealing and associated products, you are assured of the highest levels of availability to keep your plant working.

Our expertise will also help you select the correct item from our range or specify the optimal customised solution.

Customer stocking programmes are available to maintain continuity and supply.

- Dedicated technical support staff / customer service
- Field based Sealing Technology application engineers and specialists
- Skilled research and development engineers
- 24 hour UK call out service available
- Multi national locations to support our global customer network



Product Design

In an environment dedicated to innovation and free thought, our highly talented design team, work with the latest 3D CAD tools to capture design intent with your engineers.

This technology proves an invaluable tool in communicating and developing conceptual solutions involved in co-engineering partnerships; we can share 3D data in many standard formats including IGES and STEP.

Change control and configuration management techniques are used to ensure that the design intent is fully

embodied into the finished product; with our combined visual and CMM dimensional measurement system being programmed from the original 3D CAD model.

Finite Element Analysis (FEA)

Using FEA as a mathematical technique to predict deflection strain, stress, reaction force and contact pressure based on dimensional information, physical constraints and material properties improves design integrity and speed. Our Materials Technology Centre can generate temperature specific,

validated, hyper-elastic material models on which to base these analyses. FEA allows our engineers to rapidly iterate to optimal design solutions, minimising product development time and cost.

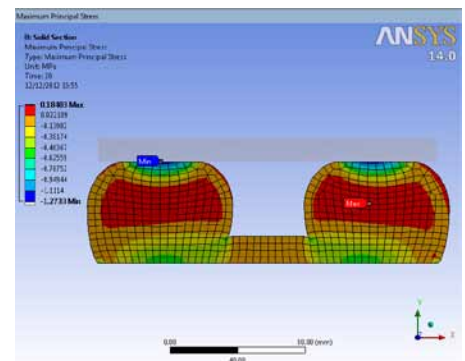

Test and Validation

We run test programmes to SAE standard specifications, our own demanding internal validation standards, customer specific requirements and special test programmes for development projects or competitor benchmarking.

Summary of standard test capability

Maximum Seal OD:	250mm
Speed:	20,000 r.p.m. (max), Cycles up to 7,000 r.p.m. (max)
Rotation:	Clockwise/Anti-clockwise
Orientation:	Shaft or housing rotation
Pressure:	0-10 bar (water, oil, air)
Temperature:	-40°C up to +200°C
Shaft Eccentricity:	Adjustable up to 1 mm
Housing Offset:	Adjustable up to 2 mm
Torque Measurement:	Max 20 Nm
Data Logging:	Speed, temperatures and pressures
Environmental:	Slurry, dust, water



Material Technology Centre

The Material Technology Centre's principal activities are to ensure our high quality standards are maintained and to develop new compounds or technical solutions for your applications.

Situated in Warrington this facility benefits from continuous investment in technology and people and is one of the major factors in ERIKS Sealing Technology's success.

Capabilities:

- Hardness (°IRHD/Shore A)
- Compression-set
- Mechanical property testing
- Chemical and heat ageing
- Ozone resistance
- Material composition
- Dimensional measurements
- Surface defects
- Material properties at temperatures from -70°C to 300°C
- Wet bench analysis
- Extraction testing
- Failure analysis
- Hyper elastic material characterisation
- Immersion testing
- UV resistance
- DMTA – Dynamic Mechanical Thermal Analysis

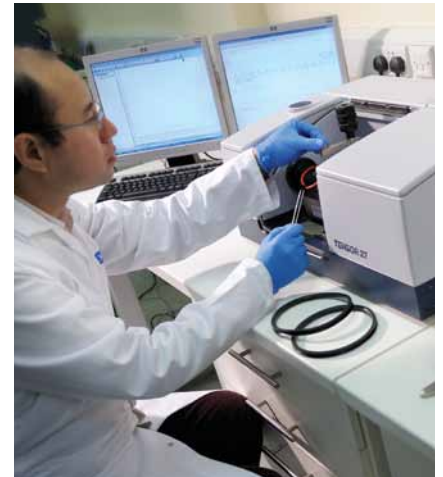

- Abrasion resistance
- Compression Stress Relaxation
- Internal mixers
- Compression moulding
- 2-Roll mills

Fourier Transform Infra-red Spectroscopy (FTIR)

Molecules have specific frequencies at which they naturally rotate or vibrate. By exposing a material sample to a spectrum of infra-red frequencies the equipment can identify which molecules are present by detecting which frequencies are absorbed. This technique is used to identify the base polymers material type in quality control and to identify thermo-chemical decomposition.

Thermo-Gravimetric Analysis (TGA)

TGA is used to identify weight loss of a compound either isothermally over time or over a ramped temperature range. The relative composition of compounds can be identified, to quantify polymer, organic and inorganic filler contents and types.

Differential Scanning Calorimetry (DSC)

DSC analysis measures changes in enthalpy (exothermic or endothermic energy changes) over time, or, with changes in temperature. DSC analysis can be used as a quality tool (residual cure), an analytical tool (failure analysis), or in development of new materials (glass transition, oxidation etc).

With modulated DSC (MDSC), the samples are subjected to a non-linear heating/cooling regime (i.e. sinusoidal). This non-linear temperature profile allows the measurement of heat-capacity effects simultaneously with the kinetic effect, as well as increasing the sensitivity of the system. With the MDSC, overlapping events can also be separated, i.e. measurement of the T_g and molecular relaxation.

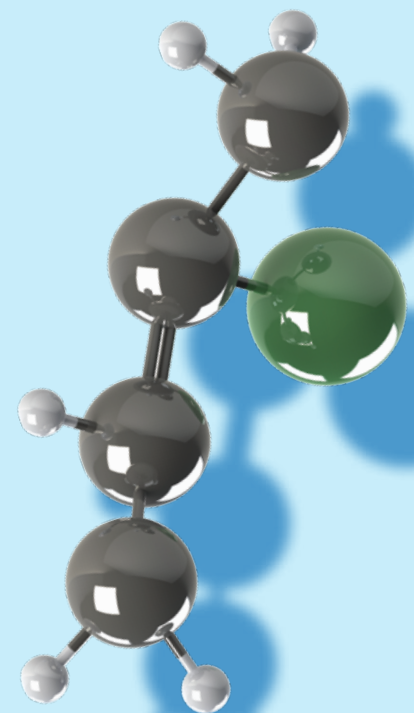

Elastomers

Elastomeric materials are described as having non-linear, viscoelastic behaviour, this means that they exhibit elastic recovery, time dependent behaviour and the relationship between load and deflection is not linear.

Elastomers used in sealing are often described as compounds, meaning that they are a mixture of ingredients manufactured under specific conditions.

Compounds typically comprise of:

- Polymer backbone – a long chain of molecules made up of one or more monomeric units, this governs the basic thermal, chemical and physical properties of a compound. ISO and ASTM classifications define families of elastomer such as NBR, FKM etc.
- Cross-link – polymer chains are tied together by cross-links; short chains of molecules e.g. sulphur, to prevent chain slippage and create elastic behaviour. Different cross-link systems will fundamentally change thermo-chemical or physical properties.
- Fillers – organic or inorganic solid particles with specific shapes and chemistries that tailor physical properties such as tensile strength, hardness, elongation at break, modulus and compression-set.
- Other ingredients - used to achieve specific manufacturing, application or cost requirements.

A typical HNBR 70 Shore A compound may have 20 ingredients and may contain only 30% polymer by weight. Therefore it is important not just to specify the family of polymer backbone and hardness, but to specify an individual compound / grade in order to achieve consistent performance.

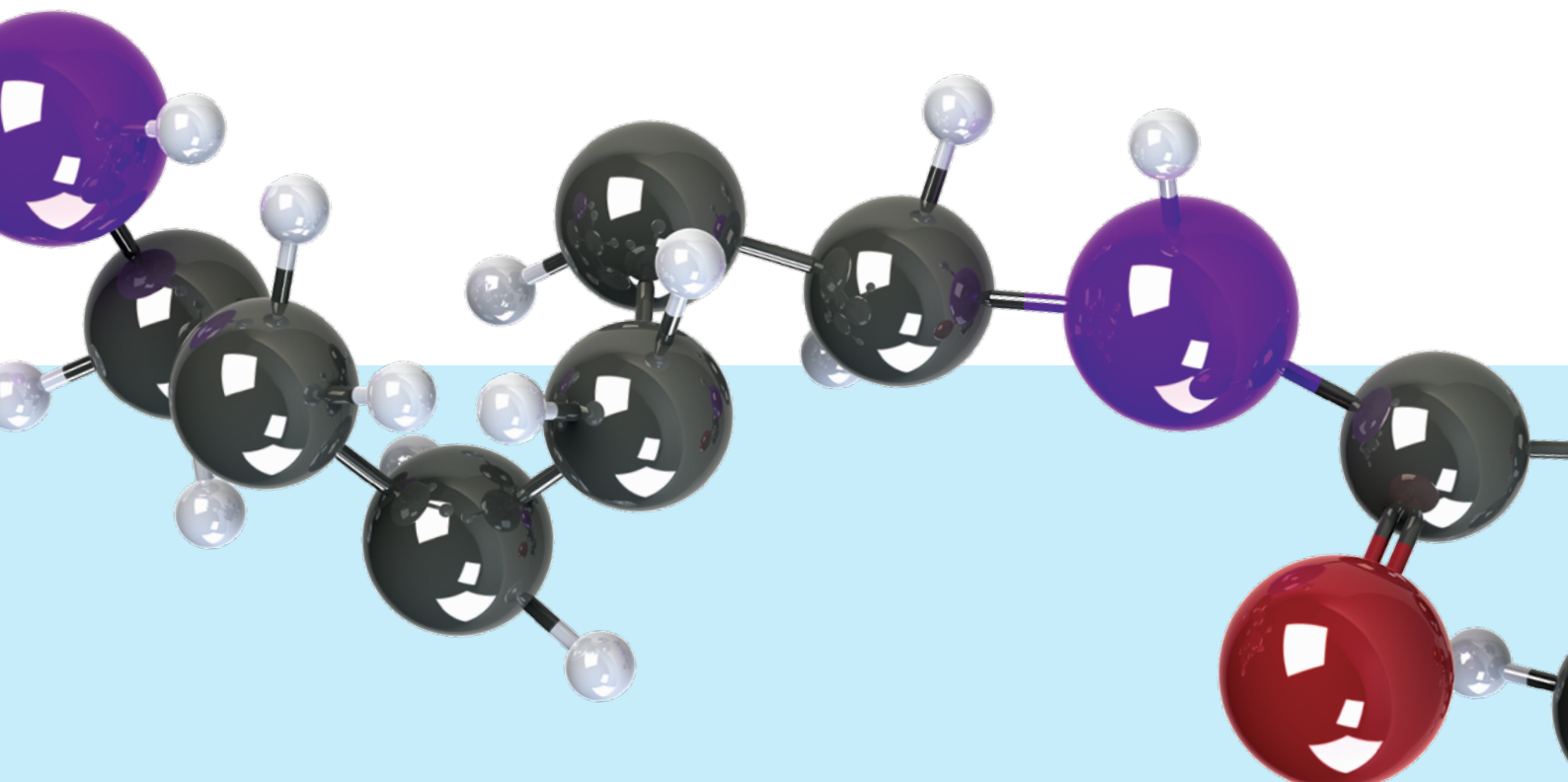

Polychloroprene (Neoprene Rubber, CR)

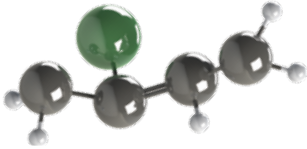

Neoprene (CR) rubbers are homopolymers of chloroprene (chlorobutadiene), and were among the earliest synthetic rubbers used to produce seals. CR has good ageing characteristics in ozone and weather environments, along with abrasion and flex-cracking resistance.

Most elastomers are either resistant to deterioration from exposure to petroleum based lubricants, or to oxygen; Neoprene is unusual, in offering a degree of resistance to both. CR also offers resistance to refrigerants, ammonia, Freon® (e.g. R134A), silicone oils, water, ozone, alcohols and low-pressure oxygen. This, combined with a broad temperature range and moderate cost, accounts for its desirability in many seal applications. CR is not effective in aromatic and oxygenated solvent environments and offers only limited resistance to mineral oils. As CR has a halogen incorporated in its backbone, such grades can offer a degree of inherent flame retardancy.

Nitrile (NBR)



Nitrile (often referred to as Buna-N) is the most commonly used elastomer in the seal industry and is a copolymer of two monomers; acrylonitrile (ACN) and butadiene. The properties of this elastomer are ruled by the ACN content which is broken down into three classifications:

High Nitrile:	>45% ACN content
Medium Nitrile:	30 – 45% ACN content
Low Nitrile:	<30% ACN content

The higher the ACN content, the better the elastomers resistance to hydrocarbon oils. With lower ACN content, the material offers better flexibility at low temperatures. Medium nitrile is, therefore, the most widely specified due to its good overall balance in most applications. Typically, nitrile rubber can be compounded to work over a temperature range of -35°C to +120°C and is superior to most other elastomers in regard to compression set, tear and abrasion resistance. Nitrile rubbers possess excellent resistance to oil-based fluids, vegetable oils, greases, water and air.

Hydrogenated Nitrile (HNBR)



Hydrogenated nitrile rubber (HNBR) is a highly saturated copolymer of acrylonitrile (ACN) and butadiene.

The properties of HNBR are dependent upon the acrylonitrile content and degree of hydrogenation (saturation) of the butadiene copolymer. They have better oil and chemical resistance than nitrile rubber and withstand higher temperatures. HNBR has excellent resistance to hot water, steam and ozone. Mechanical properties (e.g. tensile and tear strength, elongation, abrasion resistance, compression set etc.) are also excellent and compounds display strong dynamic behaviour at elevated temperatures.

HNBR can either be cured with sulphur or with peroxide, depending on which properties are the most important. Typical applications include O-rings, dynamic seals and gaskets. Limitations include poor electrical properties, poor flame resistance and swelling with aromatic oils.

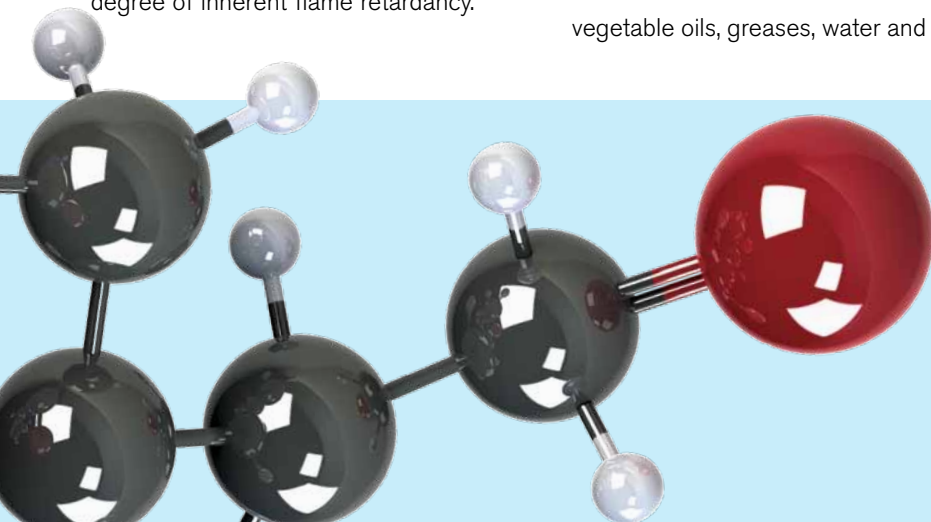

Fluorocarbon Rubber (FKM, Viton®)

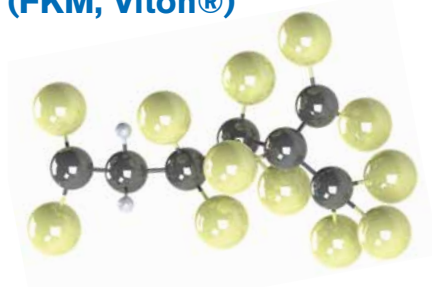

FKMs (sometimes known as FPMs in Europe) are frequently used to resist extreme temperatures and harsh chemicals. The strong carbon-fluorine bonds that make up the polymer structure provide high thermo-chemical resistance, giving excellent ageing characteristics shown by low compression set at elevated temperatures.

FKMs offer excellent resistance to mineral oils and greases, aliphatic, aromatic and some chlorinated

hydrocarbons, fuels, silicone oils and greases. However FKMs show poor resistance to ethers, ketones, esters and amines.

FKMs are available as a copolymer (two monomers), terpolymer (three monomers) or as a tetrapolymer (four monomers). Each type determines both fluorine content and chemical structure which in turn significantly impact the chemical resistance and temperature performance of the polymer.

Also related to the chemical resistance of the different types of fluoroelastomer is the cure system utilised. Bisphenol cure systems are common with the copolymer family; this system is a condensation reaction, which can be reversed when exposed to steam, hot water etc. Terpolymers or tetrapolymers are most commonly cured using peroxide based systems, which offer significant improvements in steam and water resistance.

Types of Fluorocarbon Rubber

ASTM D1418 Designation	Common Name	Typical Cure system	Typical Fluorine Content	Description
Type 1	Viton® A	Bisphenol or amine	66%	General purpose with excellent mechanical properties
Type 2	Viton® B, F or GF	Bisphenol, amine or peroxide	66 - 70%	Improved fluid and oil/solvent resistance, including improved fuel resistance. Peroxide cured materials offer improvements in coolant and water resistance
Type 3	Viton® GLT	Peroxide	64 - 67%	Improved low temperature resistance but reduced chemical resistance
Type 4	Aflas®	Peroxide	55%	Excellent resistance to lubricating oils, corrosion inhibitors and coolants.
Type 5	Viton® ETP	Peroxide	67%	Speciality grade, excellent chemical resistance, including increased resistance to amines and fuel additives.

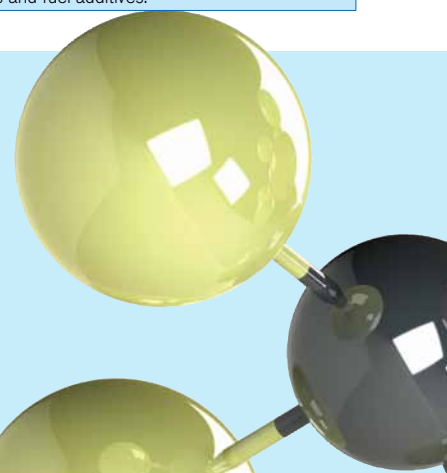

Perfluoroelastomers (FFKM)

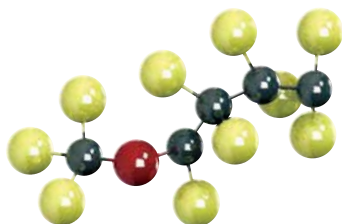

Perfluoroelastomers (FFKM) have a fully fluorinated polymer backbone resulting in a fluorine content >71%. As the material is free from carbon-hydrogen bonds in the polymer chain, the FFKM materials offer the ultimate thermo-chemical resistance.

This is demonstrated by the good long-term, high-temperature, compression-set

resistance. Chemical resistance is second to none, with good performance in a broad variety of harsh environments

Although all FFKM polymer backbones are fully fluorinated, the cross-linking systems used to join the polymer chains together differ significantly, resulting in varied temperature and chemical resistance.

Aflas® (FEPM)

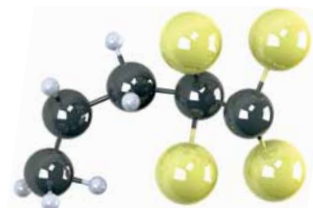

The most common forms of Aflas® (100 or 150 series) are categorized within ASTM D 1418-01 as FEPM. These grades are alternating copolymers of tetrafluoroethylene and propylene, with a fluorine content of ~54%. Such chemical structures offer excellent heat resistance, exceptional chemical resistance (significantly to alkalis and amines), along with high electrical resistivity.

Aflas® compounds are resistant to a wide range of chemicals such as acids, alkalis and steam, offering superior resistance to strong bases in comparison with FKM.

Types of Perfluoroelastomers

Common FFKM Types		
Peroxide	240°C	Broad chemical resistance.
Triazinic	327°C	High temperature, excellent mechanical properties. Reduced chemical and steam resistance.
Modified Triazinic	275°C	Broad chemical resistance, excellent mechanical properties.
Modified Peroxide	325°C	High temperature resistance, excellent mechanical properties, reduced amine and base resistance.

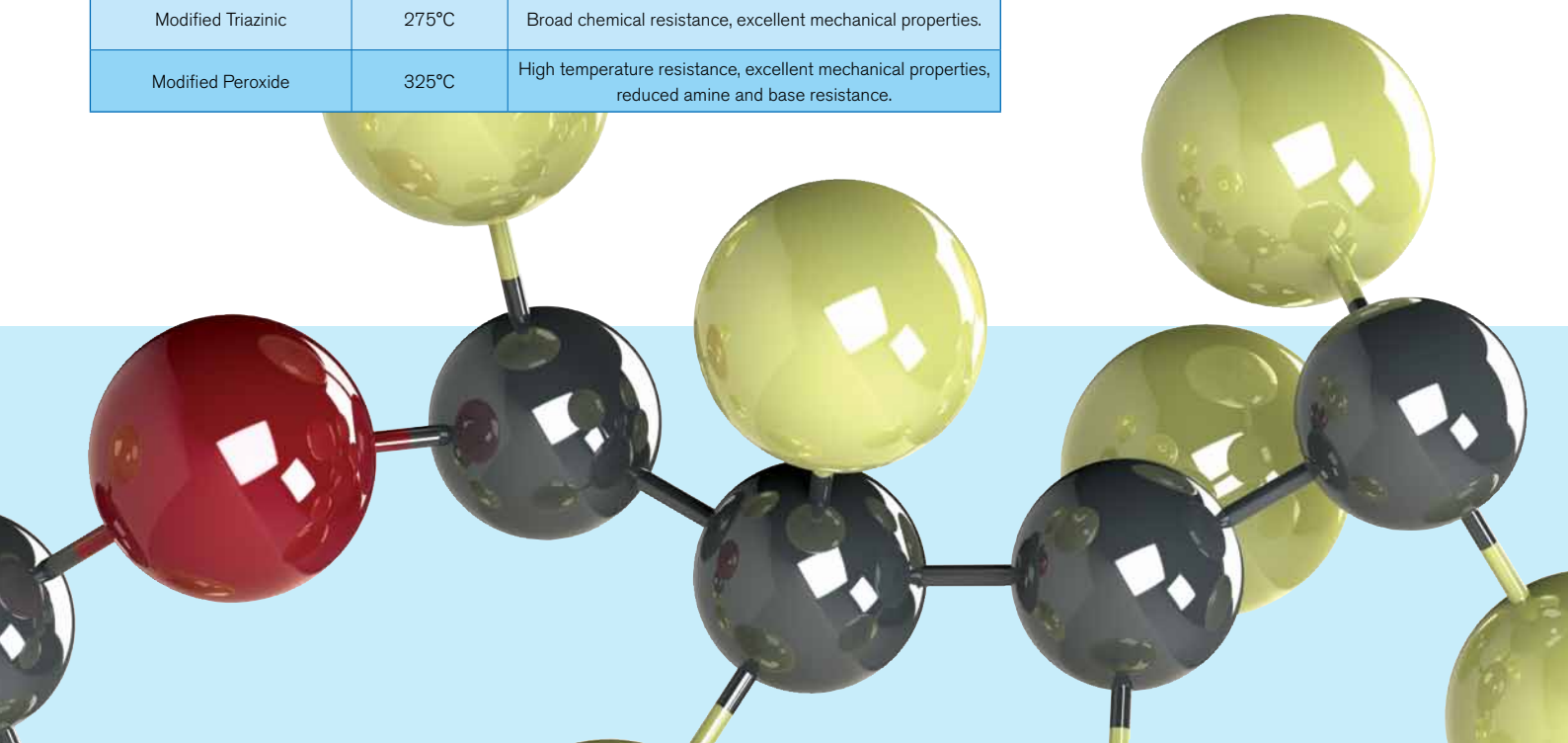

Ethylenepropylene Rubbers (EPM, EPDM)

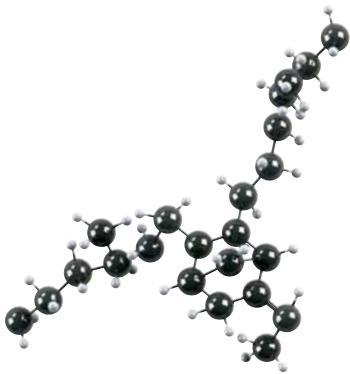

Ethylenepropylene based rubbers are forms of non-polar synthetic rubbers. EPM (sometimes also known as EP) rubber is based on ethylene and propylene monomers, with no unsaturation (carbon-carbon double bonds) present. EPDM is also based on the same constituent monomers, however as no unsaturation is present in the backbone, it is added as a third monomer,

pendent to the main chain. EPDM materials can be cured with either sulphur or peroxide; sulphur offers improved mechanical properties and peroxide enhanced heat stability. EPM rubber can only be cured using free-radicals (peroxide or radiation curing). As the polymer chains of both EPM and EPDM have completely saturated hydrocarbon backbones, excellent ozone resistance and very good resistance to heat and oxidation are achieved.

Being non-polar elastomers, EPM and EPDM offer good performance in polar fluids such as alcohols, water, steam, coolants etc., but perform badly in non-polar fluids such as hydrocarbon oils, lubricants and greases.

Silicone (VMQ)

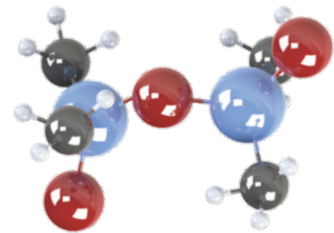

Silicone elastomers are commonly used for extreme temperature ranges (-90°C to +230°C) and offer good low temperature flexibility. They also offer resistance to ultra violet radiation (UV), oxygen and ozone.

Silicone is best suited to non-dynamic applications, as this elastomer type possess relatively low tear strength and abrasion resistance, although higher strength grades are available. They are also resistant to many mineral oils.

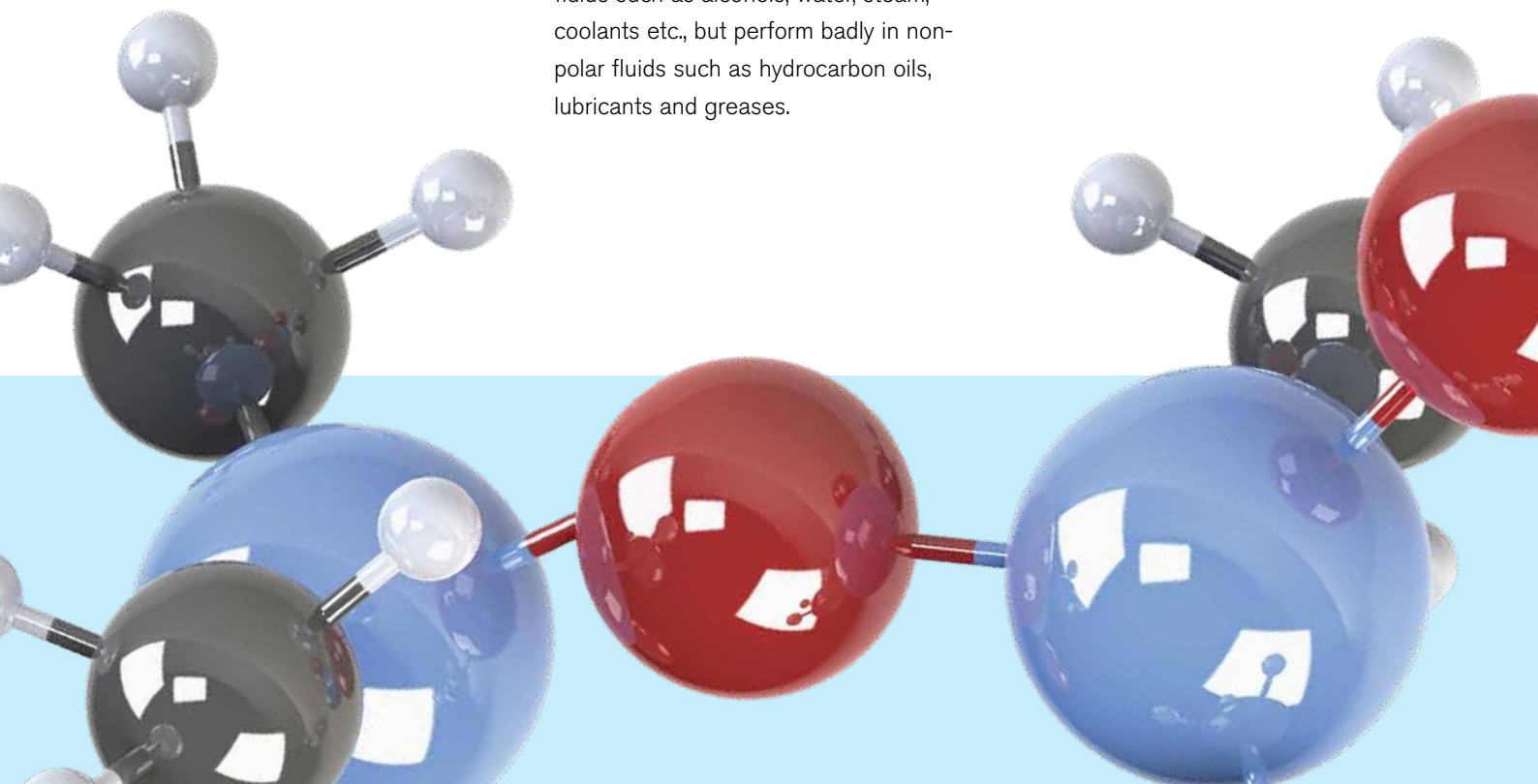

Polyurethane (AU, EU, PU)

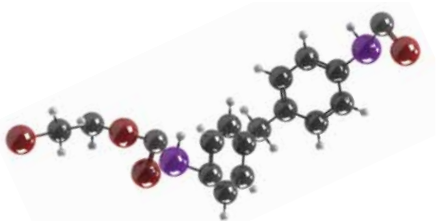

Polyurethane is a polymer formed from a chain of organic units joined by urethane links. Polyurethanes are produced by the addition reaction of a polyisocyanate with a polyalcohol (polyol) in the presence of a catalyst and other additives.

Polyurethane demonstrates excellent resistance to weathering and oxidation. They resist hydrocarbon fuels and mineral oils, however some grades degrade (hydrolyse) in hot water. Polyurethane also offers some of the best resistance

to abrasion, and are therefore often specified for use in reciprocating seals.

A major contributing factor in the mechanical performance of polyurethanes is the selection of the cross-linking /chain extender agents. Millable polyurethanes can utilise the more common sulphur or peroxide cure systems; thermoplastic and thermosetting varieties use other agents, selected to optimise mechanical properties.

There are two types of polyol commonly used: polyester based or polyether based. The polyester-based systems offer the best mechanical properties and resistance to oils; this is the most common type of polyurethane. Polyether systems show better resistance to water and steam.

Polyurethane is available in filled grades to tailor mechanical properties e.g. with added MoS_2 for self lubrication.

Polyurethane Chain Extender Systems

Name	Synonym	Features / benefits
2,4 - diisocyanato - 1 - methylbenzene	TDI	General purpose; most common
4,4 - Methylenebis (phenyl isocyanate)	MDI	General purpose
1-isocyanato - 4 - (4 - isocyanato - 3 - methylphenyl) - 2 - methylbenzene	TODI	Improved mechanical properties; excellent heat resistance
1,4 - diisocyanatobenzene	PPDI	Best heat resistance

Polytetrafluoroethylene (PTFE)



PTFE (polytetrafluoroethylene) is a synthetic, thermoplastic polymer which offers exceptional chemical resistance over a wide range of temperatures and offers extremely low levels of friction.

PTFE lacks elasticity which prevents its use as an elastomeric-type sealing ring, however it is commonly used for anti-extrusion as a back-up ring, and for non-stick requirements. Owing to its low friction and excellent chemical resistance, it is also commonly used for applications such as bearings, gears, rotary seals etc.

Non-filled (virgin) grades are stable up to +260°C and are quite flexible and resistant to breaking under tensile and compressive stresses. Modified backbone grades of PTFE are available

which offer higher temperature (+315°C) and deformation resistance. PTFE is also available with fillers to enhance its physical characteristics.

Typical fillers include:

- Glass fillers for improved deformation and wear.
- Inorganic fillers (e.g. calcium silicate, wollastonite) are used in a similar manner to glass fillers, with reduced abrasiveness.
- Carbon filled for considerable wear and deformation improvement, and increased thermal conductivity.
- Carbon-fibre filled for increased wear resistance and use against non-hardened surfaces.
- Graphite or molybdenum disulphide (MoS_2) filled to lower the coefficient of friction.
- Bronze filled for excellent wear, deformation strength, thermal conductivity (reduced chemical resistance).
- Polyester filled for improved high temperature and wear resistance, for applications where running surfaces are non-hardened.
- Polyphenylenesulphide (PPS) filled for improved wear extrusion and deformation resistance.
- Polyimide (PI) fillers are used to increase wear and abrasion resistance, being polymeric the abrasion of running surfaces is reduced.
- Combinations of some of the above are also often used to offer optimal performance in service.



Fabric / Phenolic Resin Composites

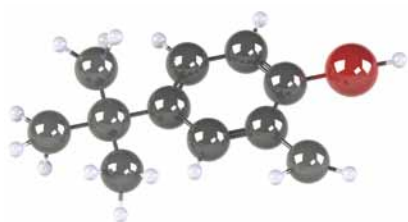

Phenolic resins, also known as phenol formaldehyde resins (PF), are synthetic thermosetting resins created by the reaction of phenols with formaldehyde. These thermosets perform well in most engineering applications such as: hydraulic fluids, oils, glycols, phosphate esters, silicone oils and brake fluids etc. Phenolic resins demonstrate high compressive strength, dimensional stability and abrasion resistance, and are commonly used in wear-ring applications as fabric resin composites.

Polyamide (Nylon)

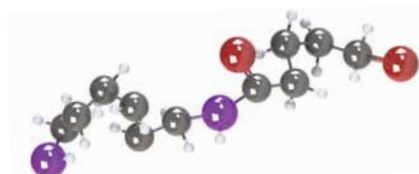

Nylon is a generic designation for a family of synthetic thermoplastic polymers known generically as polyamides, developed in 1938. Nylons are condensation copolymers formed by reacting a diamine and a dicarboxylic acid. Chemical elements included are carbon, hydrogen, nitrogen, and oxygen. The numerical suffix specifies the numbers of carbons donated by the monomers; the diamine first and the diacid second.

The most common variant is Nylon 6-6 which refers to the fact that the diamine and the diacid each donate 6 carbons to the polymer chain. The levels of these monomers has an influence on the

chemical resistance as well as the mechanical properties.

Nylon offers excellent mechanical properties in combination with good heat and wear resistance. Chemical resistance is generally broad, with good resistance to most chemicals, although Nylon can be susceptible to damage when exposed to moisture, oxidising agents or strong acids. As with other materials, combinations with fillers can often be used to improve specific properties e.g. MoS₂ for reduced friction.

Nylon is hygroscopic in nature and therefore not recommended for use in aqueous environments.

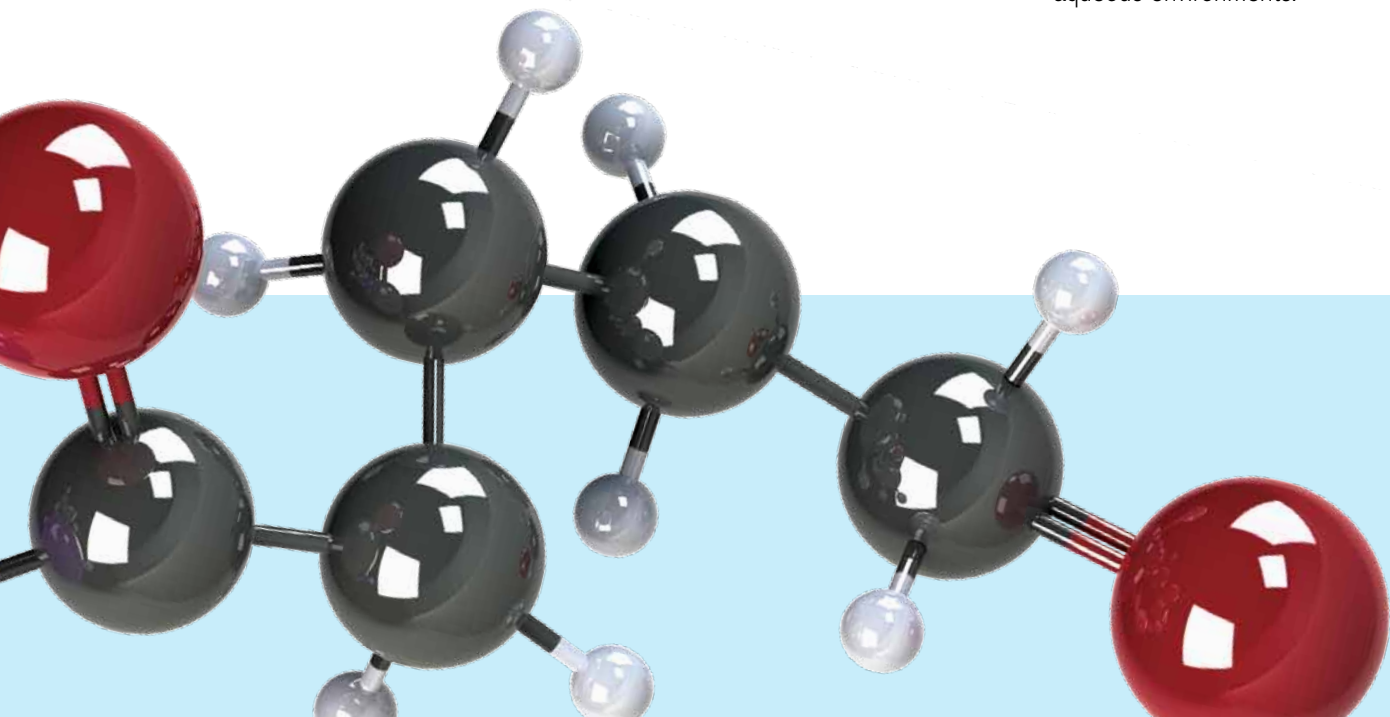

Acetal Plastic

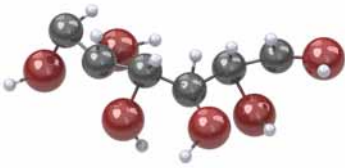

Polyoxymethylene (POM), also known as acetal, polyacetal, or polyformaldehyde. These are engineering thermoplastics used in applications that require a polymeric material with high stiffness, low friction and excellent dimensional stability. A common form of this plastic is Delrin® offered by DuPont Engineering Plastics.

The chemical composition and high degree of crystallinity result in a unique combination not found in metals or most other plastics:

- Good mechanical strength and stiffness
- Toughness and good resistance to fatigue and repeated impacts
- Excellent resistance to moisture, hydrocarbons and solvents
- Excellent dimensional stability
- Resistance to creep
- Inherent lubricity
- Operating temperature up to ~80°C

Typical applications include impellers, couplings, seals and bearings.

Polyether ether ketone (PEEK)

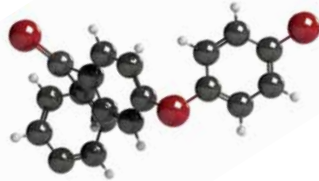

Polyether ether ketone (PEEK) is an organic, semi-crystalline, thermoplastic polymer used in demanding engineering applications. PEEK offers excellent mechanical properties, which are maintained at high temperatures. Its resistance to thermal attack and its dimensional stability at high temperatures, along with broad chemical resistance, allows PEEK to be used in applications such as bearings, sealing back-up rings etc.

PEEK is available as non-filled ('virgin') grades, and as various filled grades which modify its physical and mechanical characteristics.

- Virgin grades offer high impact resistance as well as a degree of recovery.

- Glass-filled PEEK grades have increased compressive strength and shear strength at elevated temperatures.
- Carbon-filled grades have enhanced compressive strength, tensile strength and wear-resistance.
- PTFE-filled PEEK offers a reduced coefficient of friction.
- Graphite-filled PEEK reduces the friction of the materials, improving the 'glide' properties.

Combinations of some of the above are also often used to offer optimal performance in service.

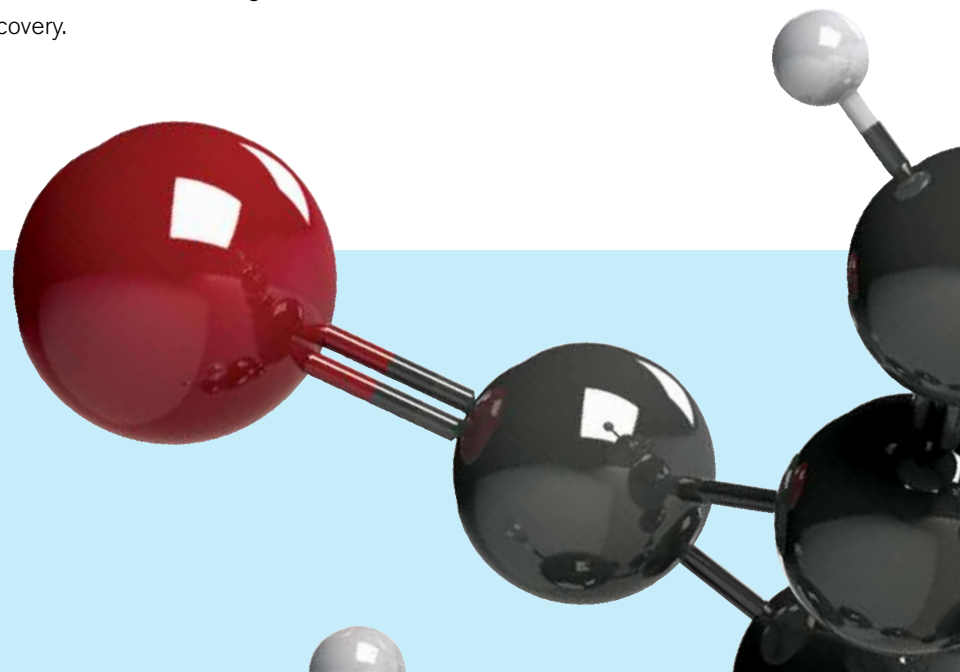

Polyimide (PI)



Polyimide (sometimes abbreviated PI) is a polymer based upon imide monomers. They are available in both thermoplastic and thermosetting forms, although the most common is the thermosetting version used for engineering applications. Thermosetting polyimides are known for thermal stability, good chemical resistance, excellent mechanical properties, and characteristic colour.

Typical polyimide components are not affected by most commonly used solvents and oils (including hydrocarbons, esters, ethers, alcohols etc.). They resist weak acids, however, are not recommended for use in steam, alkalis or inorganic acids.

Polyimide is available in both virgin and filled grades that modify physical and mechanical characteristics. Typical fillers include graphite, MoS₂ or PTFE for enhanced frictional properties, and glass or Carbon-fibre for increased strength.

Un-filled polyimides demonstrate excellent mechanical properties, but when compounded with graphite or glass fibre reinforcements, have flexural strengths in excess of 300 MPa, flexural moduli of >20 GPa and exhibit very low creep and high tensile strength.

These properties are maintained during continuous use up to temperatures of ~230°C, and also for short periods of time up to 480°C

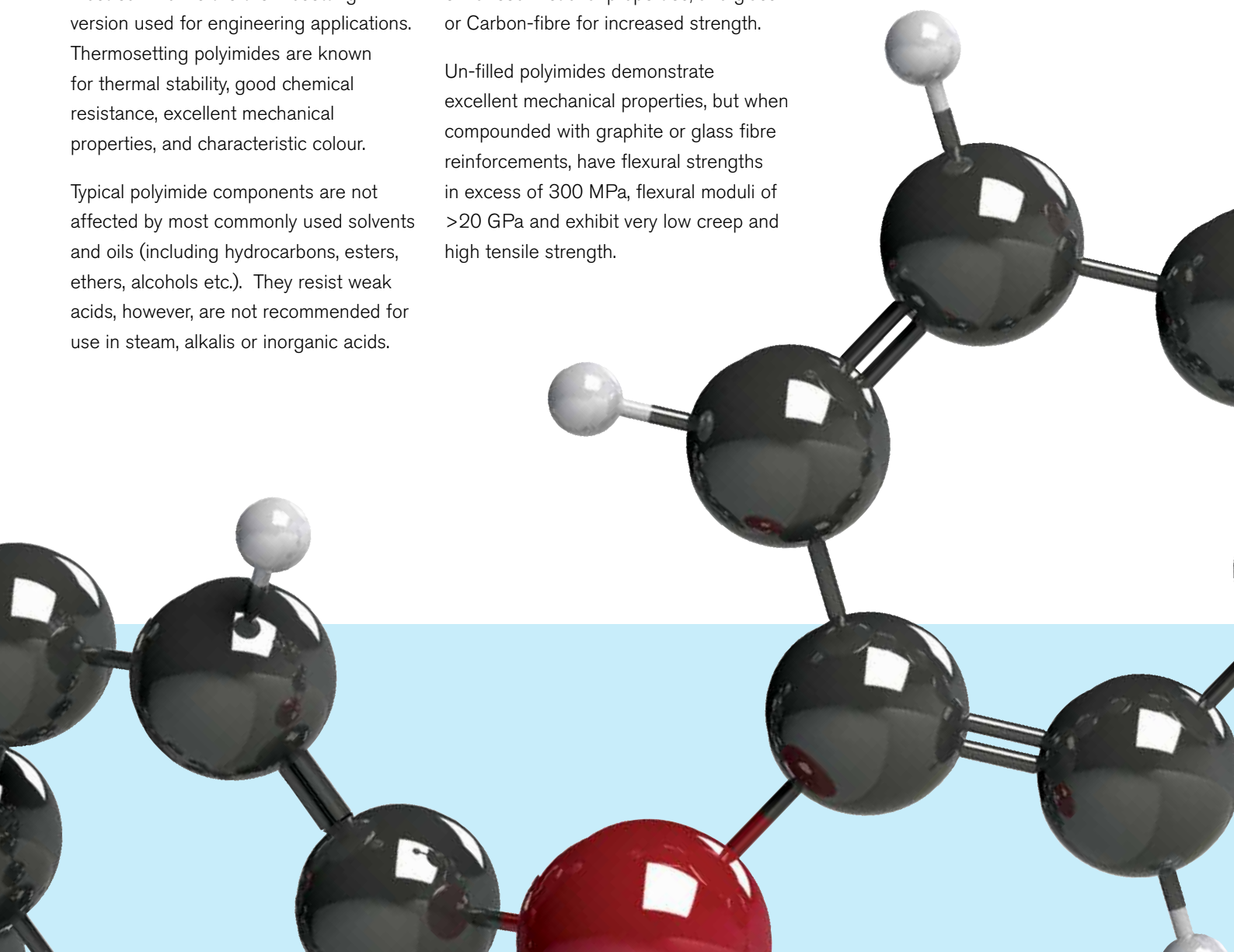

Selection of Standard ERIKS Compounds

A range of different ERIKS compounds developed for specific applications

Elastomer	Compound Reference	Colour	Hardness	Temperature	Application
Nitrile, NBR, Buna N	36624	Black	70	-35 to +110°C -31 to +230°F	Standard compound with good compression-set values and medium acrylonitrile content for use with hydraulic oils, vegetable oils, animal fats, acetylene, alcohols, water, air, fuels and many other fluids.
	47702	Black	90	-25 to +110°C -13 to +230°F	Similar to 36624 with higher hardness for higher pressure applications.
EPDM	55985	Black	70	-45 to +150°C -49 to +320°F	High performance, peroxide cured EPDM compound with excellent compression set. For use with water, steam, solvents, alcohols, ketones, esters etc. Not recommended for vegetable or mineral oils.
Hydrogenated Nitrile, HNBR	886510	Black	70	-40 to +150°C -40 to +320°F	Low temperature HNBR, offering good hydrocarbon resistance and high temperature performance. Good abrasion resistance.
Fluorocarbon FKM, A-Type	51414	Black	75	-20 to +200°C -4 to +392°F	General purpose compound with very low compression-set characteristics at high temperatures and chemical resistance to oils, fats, fuels. Suitable for vacuum applications.
	51414G	Green	75	-20 to +200°C -4 to +392°F	General purpose compound with very low compression-set characteristics at high temperatures and chemical resistance to oils, fats, fuels. Suitable for vacuum applications.
	514320	Black	90	-20 to +200°C -4 to +392°F	Similar to 51414 with higher hardness for higher pressure applications.
FKM, GF-Type	514141	Black	75	-10 to +200°C +14 to +392°F	FKM GF- Type Terpolymer with improved steam and temperature resistance.
Perfluoroelastomer, FFKM	FFKM-75-162	Black	75	+275°C +527°F	Broadest range of chemical and temperature resistance for chemical processing industry. Suitable for acids, basics, amines, steam, ethylene oxide and many other aggressive chemicals.
	FFKM-75-164	Black	75	+310°C +590°F	High temperature compound with superb compression-set characteristics and improved resistance against steam and amines. Very suitable for temperature cycle applications.

Physical Properties of ERIKS Compounds

Technical Data	36624	47702	55985	886510	51414	51414G	514320	514141	FFKM-75-162	FFKM-75-164
Colour	Black	Black	Black	Black	Black	Green (RAL 6011)	Black	Black	Black	Black
Hardness (ISO 48 Method M) ± 5 °IRHD	70	90	70	70	75	75	90	75	75 (Shore A)	75 (Shore A)
Specific Gravity	1.25	1.25	1.12	1.24	1.85	2.07	1.87	1.88	–	–
Minimum operating temperature °C	–30	–30	–45	–40	–20	–20	–20	–10	–	–
TR-10 °C	–22	–22	–40	–33	–16	–16	–16	–16	–	–
Maximum operating temperature °C	120	120	150	150	200	200	200	200	275	310
Tensile strength MPa	13	16	15.2	20	13	12	14	19.3	14	13
Elongation %	250	150	188	340	170	170	120	328	130	137
Compression-set (ISO 815 method A)										
Test time (hours)	22	22	22	22	24	24	24	22	70	70
Test temperature °C	100	100	150	150	200	200	200	175	200	200
Result – Slab %	12	13	14	12	12	14	14	14	–	–
Result – O-ring 3.53 mm %	20	25	15	16	18	19	18	–	14.2	22.9
Heat Ageing (ISO 88)										
Test time (hours)	70	70	70	20	70	70	70	70	–	–
Test temperature °C	100	100	125	150	200	200	200	250	–	–
Hardness change °IRHD	6	4	2	–2	4	5	5	4	–	–

Common chemical compatibilities of materials

	NBR	HNBR	CR	ACM	AEM	PU (AU or EU)	FKM (A)	FKM (GF)	VMQ	FKM (low temp)	EDPM	FEPDM	FFKM	Phenolics	Nylon	PPS	PEEK	Polyimide (e.g.Vesp)	PTFE
Alcohols (not methanol)	1	1	1	4	3	4	1	1	2	1	1	1	1	2	1	1	1	1	1
Aliphatic hydrocarbons	1	1	2	1	2	2	1	1	3	1	4	1	1	1	1	1	1	1	1
Alkalis (bases)	2	1	2	3	3	3	3	3	3	3	1	1	1	2	1	2	1	2	1
Alkanes	1	1	2	1	2	2	1	1	3	1	4	1	1	1	1	1	1	1	1
Amines	3	2	3	3	3	3	4	4	3	4	1	1	1	3	1	2	1	2	1
Aromatic hydrocarbons	4	4	4	2	3	3	2	1	3	1	4	3	1	2	2	2	1	1	1
Base oil	1	1	2	1	1	2	1	1	3	1	4	1	1	1	1	1	1	1	1
Biocide - conc.	3	3	2	4	4	1	3	3	3	3	2	2	1	1	3	1	1	1	1
Biocide - dilute	1	1	1	2	2	1	2	2	3	2	1	1	1	1	2	1	1	1	1
Bioethanol	2	2	1	4	3	4	3	1	2	1	1	1	1	2	1	1	1	1	1
Brake fluid - DOT, 3 and 5.1 types	3	3	2	4	4	4	4	3	3	3	1	2	1	1	1	1	1	1	1
Brake fluid - DOT 5 type	1	1	1	1	1	1	1	1	4	2	1	1	1	1	1	1	1	1	1
Cement	2	1	2	3	3	3	2	1	3	1	1	1	1	1	1	1	1	1	1
Corrosion inhibitors	3	2	3	3	3	3	4	4	3	4	1	1	1	3	1	1	1	1	1
Diesel fuel	1	1	2	1	1	2	2	1	4	1	4	1	1	1	1	1	1	1	1
Engine lubricating oils	1	1	2	1	2	1	1	1	3	1	4	1	1	1	1	1	1	1	1
Ester based hydraulic fluids	2	1	2	4	4	3	3	3	3	3	1	2	1	1	1	1	1	1	1
Ethanol	2	2	1	4	2	4	1	1	1	1	1	1	1	2	1	1	1	1	1
Fatty acid methyl ester (FAME)	2	2	2	1	1	2	2	1	3	1	4	1	1	1	1	1	1	1	1
Fire fighting media	4	4	1	4	4	2	1	1	2	1	1	2	1	1	1	1	1	1	1
Fluorinated grease	1	1	1	1	1	1	2	3	1	2	1	2	2	1	1	1	1	1	2
Glycol-based coolants	2	1	1	4	1	3	1	1	3	1	1	1	1	1	2	1	1	1	1
Glycol-ether based brake fluids	3	3	2	4	4	4	4	3	3	3	1	2	1	1	2	1	1	1	1
Hydraulic fluid - fire resistant	2	1	2	4	4	3	3	3	3	3	1	2	1	1	1	1	1	1	1
Hydraulic fluid - HFD-R	1	1	2	1	1	2	1	1	3	1	4	1	1	1	1	1	1	1	1
Hydraulic fluid - HFD-S	1	1	2	1	1	2	1	1	3	1	4	1	1	1	1	1	1	1	1
Hydraulic fluid - HFD-U	1	1	2	1	1	2	1	1	3	1	4	1	1	1	1	1	1	1	1
Hydraulic fluid - mineral oil	1	1	3	1	1	2	1	1	3	1	4	1	1	1	1	1	1	1	1
Hydraulic fluid - oil/water emulsion (HFB)	1	1	2	1	2	2	1	1	3	1	3	1	1	1	1	1	1	1	1
Hydraulic fluid - phosphate ester	2	1	2	4	4	3	3	3	3	3	1	2	1	1	1	1	1	1	1
Hydraulic fluid - water free	1	1	2	1	1	2	1	1	3	1	4	1	1	1	1	1	1	1	1
Hydraulic fluid - water/glycol (HFC)	2	1	1	3	3	3	1	1	2	1	1	1	1	1	2	1	1	1	1
Hydraulic fluid - water/oil emulsion (HFA)	1	1	2	1	2	2	1	1	3	1	3	1	1	1	1	1	1	1	1
Liquefied natural gas (LNG)	1	2	2	3	4	1	1	1	3	1	4	1	1	1	2	1	1	1	1
Liquefied petroleum gas (LPG)	1	1	2	2	2	3	1	1	3	1	4	2	1	1	2	1	1	1	1
Lithium complex grease	2	2	3	2	2	1	1	1	1	1	4	1	1	1	1	1	1	1	1



Material information can also be found on our Chemical Compatibility tool:

<http://oring-groove-wizard.eriks.co.uk/chemicalcompatibility.aspx>

	NBR	HNBR	CR	ACM	AEM	PU (AU or EU)	FKM (A)	FKM (GF)	VMQ	FKM (low temp)	EDPM	FEPM	FFKM	Phenolics	Nylon	PPS	PEEK	Polyimide (e.g.Vesp)	PTFE
Low sulphur diesel fuel	1	1	2	1	1	2	2	1	4	1	4	1	1	1	1	1	1	1	1
Lubricant - synthetic	1	1	2	1	1	2	1	1	3	1	4	1	1	1	1	1	1	1	1
Lubricating oils (API CC-type)	1	1	2	1	2	1	1	1	3	1	4	1	1	1	1	1	1	1	1
Lubricating oils (API CD-II-type)	3	1	3	2	3	2	1	1	4	1	4	1	1	1	1	1	1	1	1
Lubricating oils (API CD-type)	1	1	2	1	2	1	1	1	3	1	4	1	1	1	1	1	1	1	1
Lubricating oils (API CE-type)	1	1	2	1	2	1	1	1	4	1	4	1	1	1	1	1	1	1	1
Methane	1	1	2	1	2	3	1	1	3	1	4	1	1	1	1	1	1	1	1
Methanol	1	1	1	4	1	3	3	1	2	2	1	1	1	1	2	1	1	1	1
Mineral oil / lubricants	1	1	2	1	2	2	1	1	3	1	4	1	1	1	1	1	1	1	1
Natural gas	1	1	2	1	2	3	1	1	3	1	4	1	1	1	1	1	1	1	1
Petroleum fuels	2	2	2	2	2	2	2	1	3	1	4	2	1	1	2	1	1	1	1
Polyalkylene glycol (PEG)	2	1	1	4	2	3	1	1	3	1	1	1	1	1	2	1	1	1	1
Polyalkylene glycol (PAG)	2	1	1	4	1	3	1	1	3	1	1	1	1	1	2	1	1	1	1
Polyol fire resistant ester oil	2	1	2	4	4	3	3	3	3	3	1	2	1	1	1	1	1	1	1
Polypropylene glycol (PPG)	2	1	1	4	1	3	1	1	3	1	1	1	1	1	2	1	1	1	1
Poly- α -olefin oil	1	1	2	1	2	2	1	1	3	1	4	1	1	1	1	1	1	1	1
Rapeseed (canola) oil	1	1	3	1	1	1	1	1	4	1	4	1	1	1	1	1	1	1	1
Salt water	2	1	1	1	1	3	1	1	1	1	1	1	1	1	2	1	1	1	1
Scale inhibitors	3	3	3	3	3	3	3	1	3	1	1	1	1	1	3	2	1	3	1
Silicone oils	1	1	1	1	1	1	1	1	4	1	1	1	1	1	1	1	1	1	1
Slurries	2	1	1	1	1	3	1	1	3	1	1	1	1	1	2	1	1	1	1
Solvent - aromatic	4	4	4	2	3	3	1	1	3	1	4	3	1	2	2	2	1	1	1
Solvent - halogenated	1	1	3	1	1	4	3	3	2	3	1	2	2	1	1	1	1	3	1
Water, room temp	1	1	1	1	1	1	1	1	1	1	1	1	1	1	1	1	1	1	1
Water / Steam 100 - 150°C	3	2	3	4	3	4	2	1	2	1	1	1	1	1	4	1	1	2	1
Water / Steam 150 - 200°C	4	4	4	4	4	4	4	1	3	1	3	1	1	2	4	2	1	3	1
Water / Steam >200°C	4	4	4	4	4	4	4	4	4	4	4	4	2	3	4	3	1	4	1
Synthetic bio-degradable ester	2	1	2	4	4	3	3	3	3	3	1	2	1	1	1	1	1	1	1
Synthetic grease	1	1	2	1	1	2	1	1	3	1	4	1	1	1	1	1	1	1	1
Synthetic oil	1	1	2	1	1	1	1	1	3	1	4	1	1	1	1	1	1	1	1
Thinners	4	4	4	3	3	4	1	1	3	1	4	2	1	1	2	2	1	1	1
Universal transdraulic fluids	3	1	3	2	3	2	1	1	3	1	4	1	1	1	1	1	1	1	1
Vegetable oils	1	1	3	1	1	1	1	1	3	1	4	1	1	1	1	1	1	1	1
Weathering / UV	2	1	1	1	1	2	1	1	1	1	1	1	1	1	1	1	1	1	1
Xylene	2	1	4	4	4	4	2	1	4	1	4	4	1	1	1	1	1	1	1

KEY:**1 = Excellent****2 = Good****3 = Poor****4 = Not recommended**

ATEX

The Directive ATEX 94/9/EC (ATEX 95) – ‘Equipment and Protective Systems intended for use in potentially explosive atmospheres’ has been mandatory since July 2003.



In December 2005, the European Sealing Association (ESA) Mechanical Seals Division offered this clarification of the ATEX terminology:

“Mechanical seals which use standard parts or modifications thereof are considered machinery elements. Only in exceptional circumstances should a mechanical seal be classified as an ATEX component. An engineered mechanical seal, in the context of ATEX, should be when a specifically designed mechanical seal (which meets the criteria of an ATEX component) has its design features based on the ignition potential of a particular service.”

The systems into which mechanical and polymeric seals are incorporated must be ATEX compliant, not the seal itself.

Water based lubricants to ISO 6743-4

Water based fluids are used as coolants for large scale equipment, however seals need lubrication where movement and pressure are seen, water alone does not offer this so additional lubricants must be added.

ISO 6743-4 (5) highlights three main water based lubricants as:

- HFA oil in water emulsion or synthetic aqueous solution in water, typically more than 80% water content, operating temperature ranges from 5°C to 55°C (42°F to 130°F).
- HFB oil in water emulsion, typically more than 40% water, operating temperatures from 5°C to 60°C (42°F to 140°F).
- HFC water polymer solutions, typically more than 35% water, operating temperature ranges from -25°C to 60°C (-14°F to 140°F).

HFD working temperature ranges -20°C to 150°C (-5°F to 300°F), including:

- HFDR synthetic anhydrous fluids composed of phosphate esters.
- HFDU polyol esters and polyalkalene glycols.

Case Study

Summary

Background:

When manufacturing large diameter steel billets, hydraulic rams are used containing HFA water based fluids. Premature seal failure was seen with catastrophic leakage every 2 weeks. High cost incurred in downtime and maintenance became an issue and a solution had to be found as quickly as possible.

Failure Analysis

The cylinder housing was measured, surface finishes checked and a failed set of seals were analysed to determine reason for failure. The failing rod seal was a NBR fabric chevron profile, accompanied by NBR wipers. The chevrons showed signs of high wear with the fabric visually seen and white in colour.

Seal profiles and sizes were correct, based on housing dimensions and surface finish and FTIR analysis showed the issue to be material compatibility with the fluid.

Fabric reinforced seals need lubrication, oil is absorbed into the fabric which keeps the NBR elastomer lubricated allowing free movement, this reduction in friction also reduces heat build up. Water based fluids will not absorb into the fabric which means no lubrication, friction equals heat build up and the end result being increased wear.

Conclusion

A hydrolysis-resistant thermoplastic polyurethane elastomer (TPU) does not require absorption to provide the required level of lubricity and is available in billet form. Seals were machined in profiles appropriate for the current housing arrangement within very short lead-times. The new seals extended the mean time between failures (MTBF) to beyond the planned maintenance schedule, removing unscheduled down-time and thus reducing total cost of ownership (TCO).

The customer was delighted, estimating their savings to be over £78K per annum in reduced down-time.

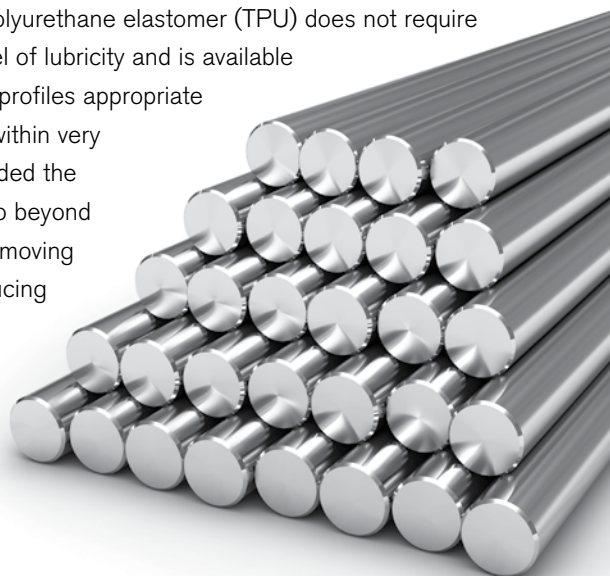

Metal Processing

Material Handling and Preparation

Applications	Requirements	Seal Profiles	Sealing Materials
Conveyor Systems	Large dimensions Broad tolerances Aggressive / Dirty / Abrasive environments	Heavy Duty Rotary seals Split Rotary seals Metal Face seals O-rings Thermo-plastic labyrinth seals Lip seals	NBR HNBR AU
Cranes & Lifting equipment	Easy installation and replacement	Heavy Duty Rotary seals Split Rotary seals Hydraulic seals Metal face seals	NBR FKM HNBR PTFE AU
Stacker Reclaimers (Slew and trench)	Large dimensions Broad tolerances Aggressive / Dirty / Abrasive environments	Heavy Duty Rotary seals Metal face seals Hydraulic seals	NBR HNBR AU
Ball mills	Large dimensions Broad tolerances Aggressive / Dirty / Abrasive environments	Heavy Duty Rotary seals Bespoke mechanical seals Hydraulic seals	NBR HNBR AU



Primary Process - (Coking / Sintering / Pelletizing)

Applications	Requirements	Seal Profiles	Sealing Materials
Pumps and Valves	Hot and abrasive conditions	Component Mechanical seals PTFE Lip seals O-rings	VMQ NBR HNBR PTFE
Rotary kilns	Hot and abrasive conditions	Heavy Duty Rotary seals	FKM HNBR
Conveyor Systems	Large dimensions Broad tolerances Aggressive / Dirty / Abrasive environments	Heavy Duty Rotary seals Split Rotary seals Metal Face seals O-rings Thermo-plastic labyrinth seals	NBR HNBR AU
Hydraulic and pneumatic cylinders / rams	Hot and abrasive conditions	O-rings Wiper seals Piston seals Bearingstrip Rod seals	FKM NBR AU POM PA PTFE



Ironmaking

Applications	Requirements	Seal Profiles	Sealing Materials
Gearboxes	Hot and abrasive conditions	Heavy Duty Rotary seals Split Rotary seals V-rings	NBR FKM HNBR PTFE
Slag taphole drills & clay guns	Abrasive conditions	Hydraulic seals O-rings	NBR FKM AU
Pumps and Valves	Hot and abrasive conditions	Component Mechanical seals PTFE Lip seals O-rings	VMQ NBR HNBR PTFE
Flow gates	Hot and abrasive conditions. Ease of replacement	Bespoke mechanical seals	Application specific
Ladles & "Torpedos"	Abrasive conditions	Heavy Duty Rotary seals Hydraulic seals O-rings	NBR FKM AU



Steelmaking

Applications	Requirements	Seal Profiles	Sealing Materials
Gearboxes	Hot and abrasive conditions	Heavy Duty Rotary seals Split Rotary seals V-rings	NBR FKM HNBR PTFE
Pumps and Valves	Hot and abrasive conditions	Component Mechanical seals PTFE Lip seals O-rings	VMQ NBR HNBR PTFE
Gas delivery systems	Permeation Oxidation resistance	O-rings	FKM VMQ
Hydraulic systems, e.g. jacks	Hot and abrasive conditions	O-rings Wiper seals Piston seals Bearing strip Rod seals	FKM NBR AU POM PA PTFE



Metal Processing

Smelting

Applications	Requirements	Seal Profiles	Sealing Materials
Pumps and Valves	Hot and abrasive conditions	Component Mechanical seals PTFE Lip seals O-rings	VMQ NBR HNBR PTFE
Roller systems (tables, balance cylinders, etc.)	Hot and abrasive conditions	O-rings Wiper seals Piston seals Bearing strip Rod seals Labyrinth seals Bespoke mechanical seals	FKM NBR AU POM PA PTFE
Anode green mills	Abrasive Water resistance	Heavy Duty Rotary seals Bespoke Mechanical seals	FKM HNBR



Continuous Casting

Applications	Requirements	Seal Profiles	Sealing Materials
Rollers and Roller bearing units	Large dimensions Broad tolerances Aggressive / Dirty / Abrasive environments	Heavy Duty Rotary seals Split Rotary seals O-rings Labyrinth seals Bespoke mechanical seals	NBR HNBR FKM AU
Roll Control and Positioning	Oil resistance Abrasive particulates	O-rings Wiper seals Piston seals Bearing strip Rod seals	FKM NBR AU POM PA PTFE
Water Cooling systems	Chemical resistance	O-rings	VMQ HNBR FKM
Pumps and Valves	Hot and abrasive conditions	Component Mechanical seals PTFE Lip seals O-rings	VMQ NBR HNBR PTFE



Rolling, Tube and Pipe

Applications	Requirements	Seal Profiles	Sealing Materials
Work-roll and back-up roll Chocks	Large dimensions Broad tolerances Aggressive / Dirty / Abrasive environments	Heavy Duty Rotary seals Split Rotary seals O-rings Labyrinth seals Bespoke mechanical seals	NBR HNBR FKM AU
Gauge Control Units	Oil resistance Abrasive particulates	O-rings Wiper seals Piston seals Bearing strip Rod seals	FKM NBR AU POM PA PTFE
Water de-scalers	Chemical resistance	O-rings	VMQ HNBR FKM
Roller systems (tables, balance cylinders, coiling tension units etc.)	Hot and abrasive conditions	O-rings Wiper seals Piston seals Bearing strip Rod seals Labyrinth seals Bespoke mechanical seals	FKM NBR AU POM PA PTFE



Treatments - Pickling, Coating and Shearing

Applications	Requirements	Seal Profiles	Sealing Materials
Pumps and Valves	Hot and abrasive conditions	Component Mechanical seals PTFE Lip seals O-rings	VMQ NBR HNBR PTFE
Rollers and Roller bearing units	Large Diameter Chemical Resistance	Heavy Duty Rotary seals Split Rotary seals Labyrinth seals Spring energised seals	NBR HNBR FKM PTFE



Metal Processing

Forging, Extrusion, Shearing

Applications	Requirements	Seal Profiles	Sealing Materials
Pumps and Valves	Hot and abrasive conditions	Component Mechanical seals PTFE Lip seals O-rings	VMQ NBR HNBR PTFE
Roller systems	Hot and abrasive conditions	O-rings Wiper seals Piston seals Bearing strip Rod seals Labyrinth seals Bespoke mechanical seals	FKM NBR AU POM PA PTFE
Ram systems	Hot and abrasive conditions	O-rings Wiper seals Piston seals Bearing strip Rod seals	FKM NBR AU POM PA PTFE
Shearing & slitting lines	Hot and abrasive conditions	O-rings Wiper seals Piston seals Bearing strip Rod seals	FKM NBR AU POM PA PTFE



Aggregates

Cement Processing / Sand Treatments / Plaster Board

Applications	Requirements	Seal Profiles	Sealing Materials
Stacker Reclaimers / Boring equipment	Aggressive / Dirty / Abrasive environments	Heavy Duty Rotary seals Metal face seals Hydraulic seals	NBR HNBR
Screw Conveyors	Large dimensions Broad tolerances Aggressive / Dirty / Abrasive environments	Heavy Duty Rotary seals Split Rotary seals Metal Face seals O-rings Thermo-plastic labyrinth seals	NBR HNBR AU
Crushers Grinders Ball Mills Screening	Large dimensions Broad tolerances Aggressive / Dirty / Abrasive environments	Heavy Duty Rotary seals Split Rotary seals Metal Face seals O-rings	NBR HNBR AU



Heavy Duty Rotating Equipment

Applications	Requirements	Seal Profiles	Sealing Materials
Compressors	High Speeds	PTFE Rotary seals	PTFE
Industrial Gearboxes	Large Diameters	Heavy Duty Rotary seals Split Rotary seal	NBR FKM
Gen Sets	High Temperatures	O-rings Heavy Duty Rotary seals	FKM FFKM
Winches	Easy installation and replacement	Heavy Duty Rotary seals Split Rotary seals Hydraulic seals	NBR FKM HNBR AU
Industrial Fans	High Speeds	Heavy Duty Rotary seals Split Rotary seal	PTFE FKM HNBR
Motors	High Temperatures Chemical resistance	V-rings Bespoke Mechanical seals Labyrinth seals O-rings	NBR FKM PTFE



Packaging Pulp, Paper and Print Processing

Applications	Requirements	Seal Profiles	Sealing Materials
Chemical Pulping Lines	Chemical compatibility (Bleaching Agents)	O-rings	FKM EPDM Atlas®
Pumps and Valves	Chemical compatibility Steam resistance	O-rings	Atlas® FKM Terpolymers HNBR EPDM FFKM
Glue/Doctor Rolls	Aggressive media	Bespoke Mechanical seals	Application specific
Paper Rolls	High Speed High Misalignment	Heavy Duty Rotary seals	NBR FKM
Impellers, Mixers and Agitators	Chemical compatibility	Heavy Duty Rotary seals Bespoke Mechanical seals Spring energised seals O-rings	FKM PTFE
Printing	Printing Ink compatibility	O-rings	EPDM NBR FKM FFKM



Heavy Duty Rotary Lip Seals

Product Overview

One of the most frequently used types of seal is the rotary lip seal, generally used for sealing lubricating oil or grease in rotary shaft applications. This is achieved by:

- Providing static sealing between the outer diameter of the seal and its housing.
- Sealing between the shaft and the main sealing lip when either static or dynamic. The radial load exerted by the sealing lip must be sufficient to retain the oil or grease, but not so high that excessive friction or wear occurs.

The principal of this can be affected by the following basic parameters and must always be taken into consideration when selecting the correct profile and material to enable the optimum performance:

- Shaft rotational speed and direction
- Operating temperature
- Application hardware details
- Medium being sealed both internally and externally
- Pressure seen within sealed unit

In addition to the heavy duty series of rotary seals in this brochure, comprehensive details of our complete rotary seal range may be found at <http://www.pioneerweston.com>



Elastomeric Lip Styles

Profile	Profile Features	Profile Advantages	Applications
R1 	<ul style="list-style-type: none"> - Ground metal outer diameter - Spring loaded primary seal lip - Additional reinforcing metal insert 	<ul style="list-style-type: none"> - Press fit metal OD for precise location in housing - Metal insert gives seal more rigidity, specifically for larger sizes 	<ul style="list-style-type: none"> - Industrial gearboxes - General Machinery
R2 	<ul style="list-style-type: none"> - Ground metal outer diameter - Spring loaded primary seal lip - Additional reinforcing metal insert - Additional dust lip 	<ul style="list-style-type: none"> - Press fit metal OD for precise location in housing - Metal insert gives seal more rigidity, specifically for larger sizes - The addition of a dust lip offers protection against low to medium dirt ingress 	<ul style="list-style-type: none"> - As above
R70 	<ul style="list-style-type: none"> - Spring loaded primary seal lip - Fabric reinforced outer diameter 	<ul style="list-style-type: none"> - Fabric reinforced outer diameter allows for easy installation and removal - Can be supplied split for in-situ replacement - Flexible sealing lip to accommodate shaft eccentricity 	<ul style="list-style-type: none"> - Industrial gearboxes - Rolling mills - Cranes / Winches - General Machinery
R71 	<ul style="list-style-type: none"> - Spring loaded primary seal lip - Fabric reinforced outer diameter - Additional dust lip 	<ul style="list-style-type: none"> - Fabric reinforced outer diameter allows for easy installation and removal - Can be supplied split for in-situ replacement - Flexible sealing lip to accommodate shaft eccentricity - The addition of a dust lip offers protection against low to medium dirt ingress 	<ul style="list-style-type: none"> - As above
R72 	<ul style="list-style-type: none"> - Machined metal outside diameter - Elastomer sealing lip with moulded-in finger spring 	<ul style="list-style-type: none"> - Robust construction for retaining grease - Low radial sealing force reduces seal wear 	<ul style="list-style-type: none"> - Cement grinders - Rolling mills
R73 	<ul style="list-style-type: none"> - Machined metal outside diameter - Steel re-enforcing ring - Spring loaded primary seal lip 	<ul style="list-style-type: none"> - Press fit metal OD for precise location in housing - Metal re-enforcing ring gives seal more rigidity - Retained garter spring along with flexible sealing lip copes with high shaft to bore misalignment / run-out 	<ul style="list-style-type: none"> - Work / Back-up rolls - Paper mills
R74 	<ul style="list-style-type: none"> - Machined metal outside diameter - Steel re-enforcing ring - Spring loaded primary seal lip - Additional dust lip 	<ul style="list-style-type: none"> - Press fit metal OD for precise location in housing - Metal re-enforcing ring gives seal more rigidity - Retained garter spring along with flexible sealing lip copes with high shaft to bore misalignment / run-out - The addition of a dust lip offers protection against low to medium dirt ingress 	<ul style="list-style-type: none"> - As above

Imperial (English)

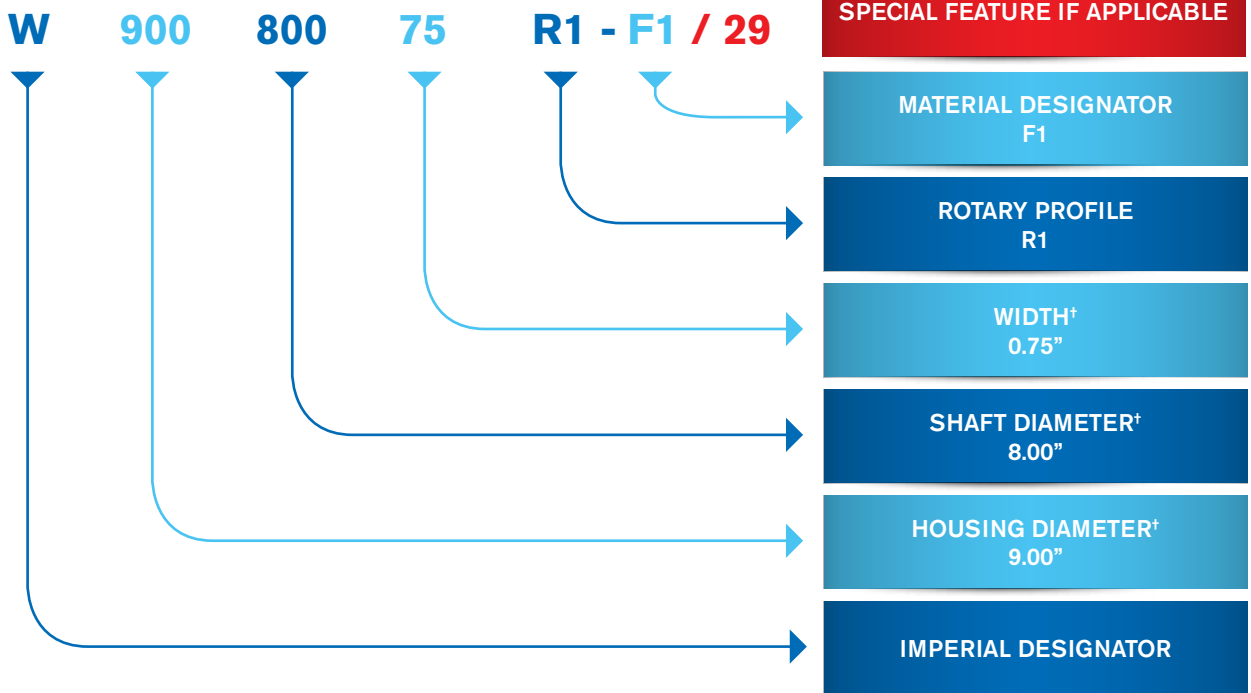

[†]Dimension rounded down to 2 decimal places then multiplied by 100

Metric

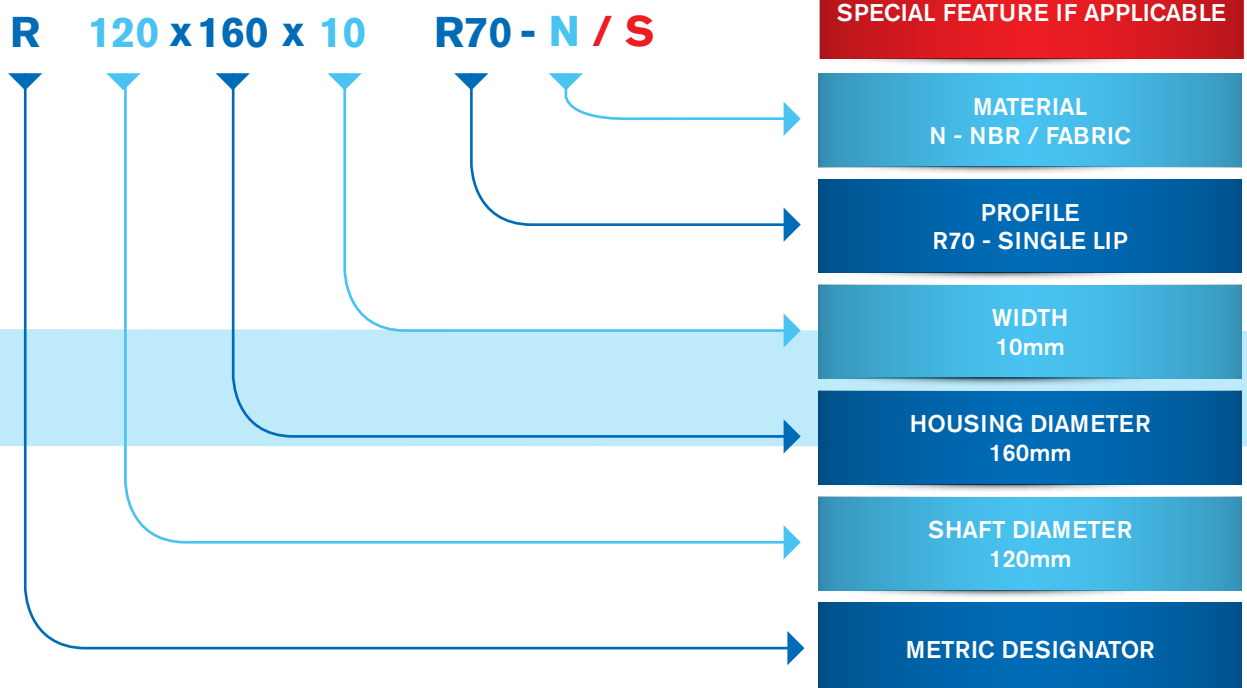

Heavy Duty Seal Elastomeric Compound Reference





Polymer Types	Compound Reference	Colour	Hardness (IRHD)	Temperature Range	Select for..	Material Designator
Nitrile rubber (NBR)	N-70-194	Black	70	-35 to +110°C	General purpose	N1
Fluorocarbon (FKM, A-type)	V-75-27	Black	75	-20 to +200°C	High temperature performance; high speed applications	F1
	V-85-195	Black	85	-20 to +200°C		F2
	V-75-50	Brown	75	-20 to +200°C		F3
	V-80-271	Black	80	-51 to +200°C	Specialist ultra-low temperature FKM	F4
	V-80-88	Black	80	-15 to +200°C	Specialist FKM terpolymer developed for use with bio-fuels	F5
Silicone (VMQ)	S-80-78	Red	80	-55 to +230°C	High and very low temperature; high eccentricity	S1
Polyacrylate (ACM)	A-70-196	Black	70	-30 to +175°C	High and low temperature capabilities; good compatibility with engine oils	A1
Hydrogenated nitrile (HNBR)	H-80-40	Black	80	-40 to +180°C	Abrasion resistance; high temperatures	H1
NBR / Fabric	-	Black	-	-35 to +110°C	General purpose / large diameter location	N
FKM / Fabric	-	Black	-	-2 to +200°C	High temperature / large diameter location	F

Other materials are available on request.

Special Features Designator

Feature	Function	Selection	Designator
Stainless steel spring	Rust and acid resistant spring	-	29
Sealant paint	Only available on metal cased seals, this sealant paint helps to seal against any housing imperfections	Red	2
		Blue	3
Split (Available only on R70 and R71)	Split to allow in-situ installation	-	S

Solid Body PTFE Seal Styles

Profile	Profile Features	Profile Advantages	Applications
R60 	<ul style="list-style-type: none"> - Solid machined steel carrier - PTFE sealing element 	<ul style="list-style-type: none"> - Press fit metal OD for precise location in housing - PTFE lip to combat greater shaft speeds, elevated temperatures and aggressive media - Available as non- standard sizes with no tooling requirement 	<ul style="list-style-type: none"> - Large motors - Industrial gearboxes - Compressors
R61 	<ul style="list-style-type: none"> - Solid machined steel carrier - PTFE sealing element 	<ul style="list-style-type: none"> - Press fit metal OD for precise location in housing - PTFE lip to combat greater shaft speeds, elevated temperatures and aggressive media - Suitable for higher pressures - Available as non- standard sizes with no tooling requirement 	<ul style="list-style-type: none"> - Unvented applications - Pumps - Large electric motors - Compressors
R62 	<ul style="list-style-type: none"> - Solid machined steel carrier - Dual PTFE sealing elements 	<ul style="list-style-type: none"> - Press fit metal OD for precise location in housing - PTFE lip to combat greater shaft speeds, elevated temperatures and aggressive media - Ideal for applications where lubrication is minimal - Available as non- standard sizes with no tooling requirement 	<ul style="list-style-type: none"> - Large fans
R63 	<ul style="list-style-type: none"> - Solid machined steel carrier - Axially opposed PTFE sealing elements 	<ul style="list-style-type: none"> - Press fit metal OD for precise location in housing - PTFE lip to combat greater shaft speeds, elevated temperatures and aggressive media - Seal for separation of two media or where liquid or viscous contaminant is present - Available as non- standard sizes with no tooling requirement 	<ul style="list-style-type: none"> - Submerged gearboxes and generators - Industrial gearboxes

Bespoke variants available to meet specific application requirements.

PTFE Grades

Material Composition	Compound Reference	Colour	Coefficient of Friction	Temperature Range	Select for..	PTFE Designator
Glass and MoS ₂ reinforced PTFE	PF-200	Grey	0.06 / 0.10	-160 to +290°C	Low wear, high life, reduced friction	E1
Graphite reinforced PTFE	PF-201	Grey / Black	0.06 / 0.10	-200 to +250°C	Soft shafts, reduced friction	E2
Carbon-fibre reinforced PTFE	PF-293	Grey / Black	-	-100 to +250°C	Low wear, improved deformation resistance	E3

Other materials are available on request.

Solid Body Carrier Materials

Metal	Shell Material Designator
Mild Steel	M
Stainless Steel	S

Imperial (English)

W 600 500 50 R60 - M / E2

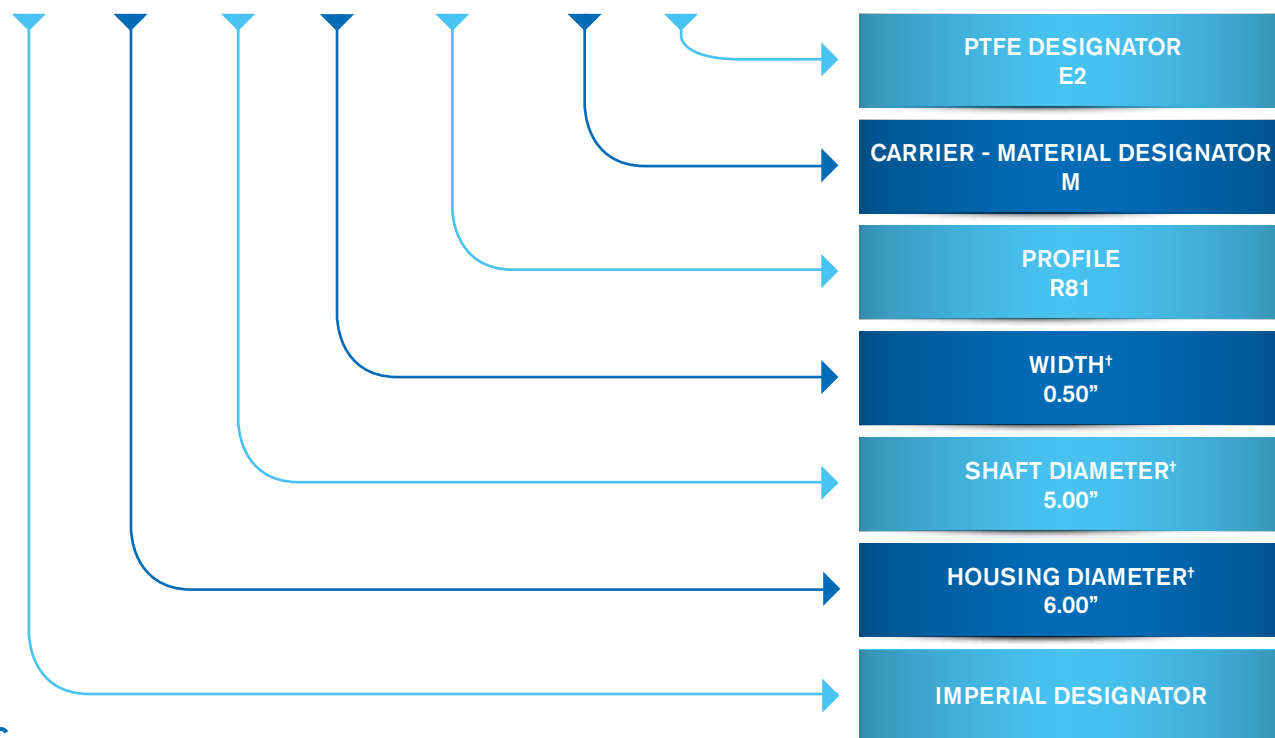

Metric

R 80 x 100 x 10 R62 - S / E1

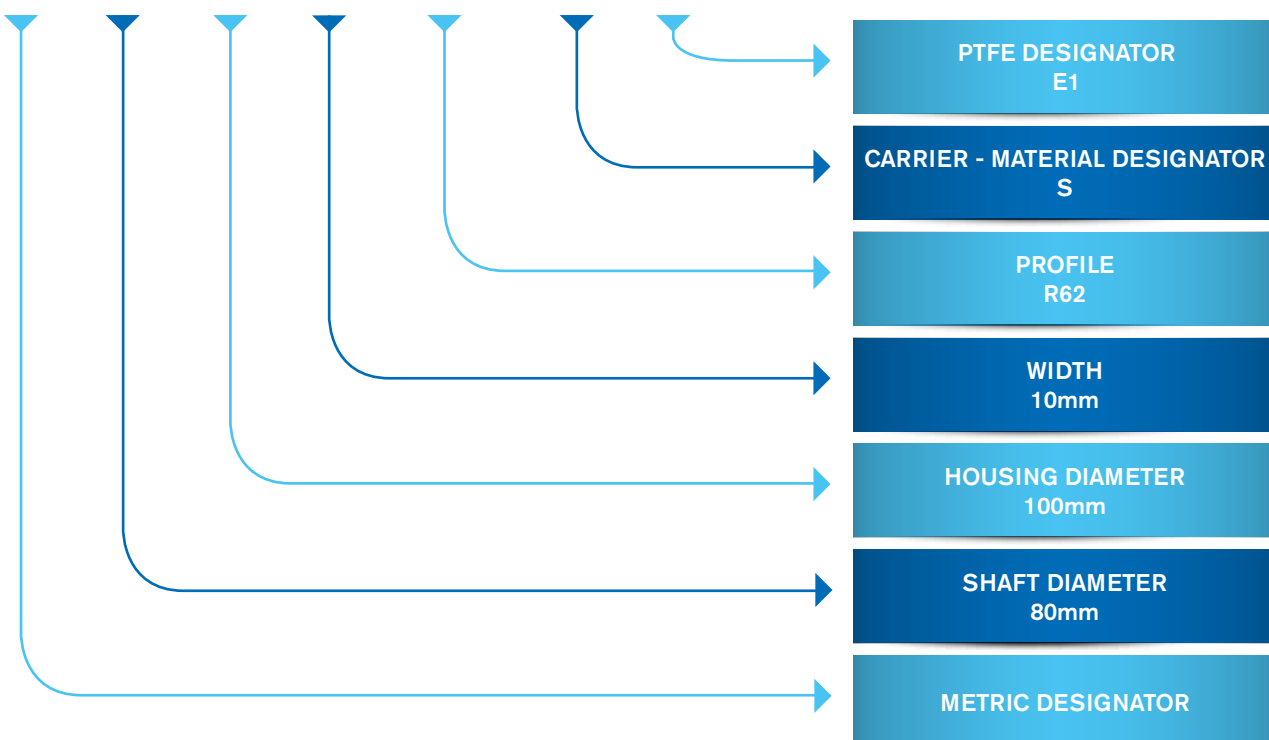

[†]Dimension rounded down to 2 decimal places then multiplied by 100

GS Split

The GS split seal is used in applications where installation and replacement mandates that the surrounding hardware cannot be fully disassembled.

Features and Benefits

- Easy installation and removal
- Suitable for very large diameters
- Robust design
- Flange design allowing accurate positioning
- Short axial length

Applications

- Large gearboxes
- Lifting gear



Maximum working conditions	
Shaft speed	12 m/s
Pressure	0.5 bar
Temperature	100 °C

Imperial (English)

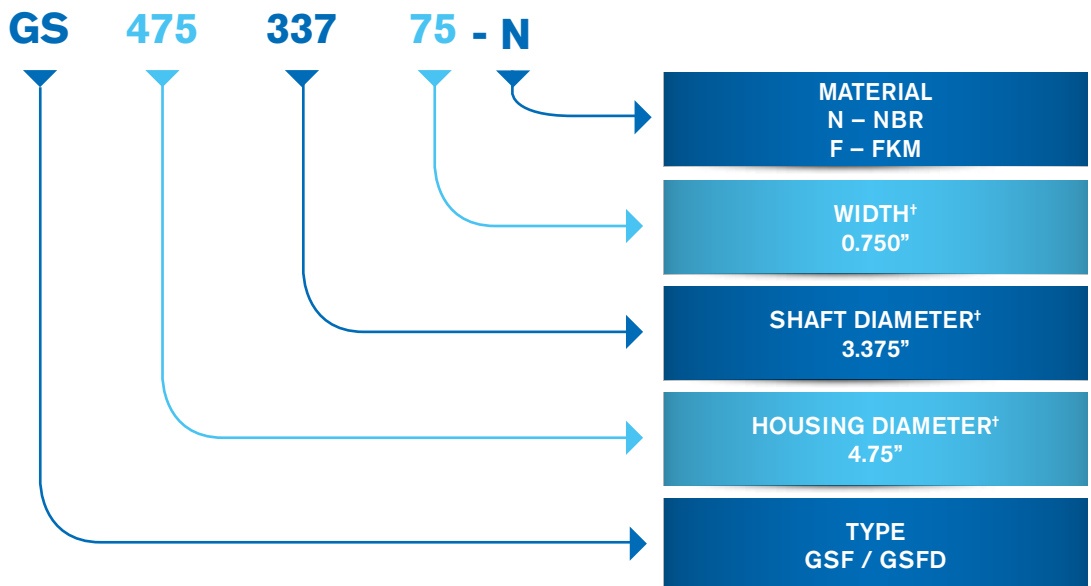

†Dimension rounded down to 2 decimal places then multiplied by 100

Metal Face Seals

Metal face seals offer bearing protection and lubricant retention on any relatively slow moving housing assembly. These seals are constructed from two identical, tapered metal rings, loaded using elastomer seals.

Such designs excel under extreme environments, where the exclusion of contaminants such as sand, rock, mud and water is imperative, providing a robust efficient solution, with long service life and low maintenance.

Features and Benefits

- Corrosion and abrasion resistant seal rings
- Special seal and load ring materials to suit application requirements
- Self-centring to compensate for shaft eccentricity or misalignment
- Cost savings from extended machinery life
- Easy to assemble and minimal maintenance
- Broad operation temperature range from -40°C to 200°C

Applications

- Conveyor systems
- Boring equipment
- Stacker / Reclaimers
- Heavy plant and grinders

Selection and Material Specification

Ensuring the correct material composition is paramount. Pioneer Weston can work with the customer to analyse application requirements and recommend the most suitable materials. The main factors in ensuring the correct selection are: size, temperature, speed, pressure and media.



Metal Ring Grades

	X	C	F
Process	Cast	Cast	Forged
Cost	High	Medium	Low
Wear Life	High	Medium/High	Low
Corrosion Resistance	High	Low/Medium	Low
Abrasion Resistance	High	Medium/High	Medium

Metal Face Seals part number breakdown

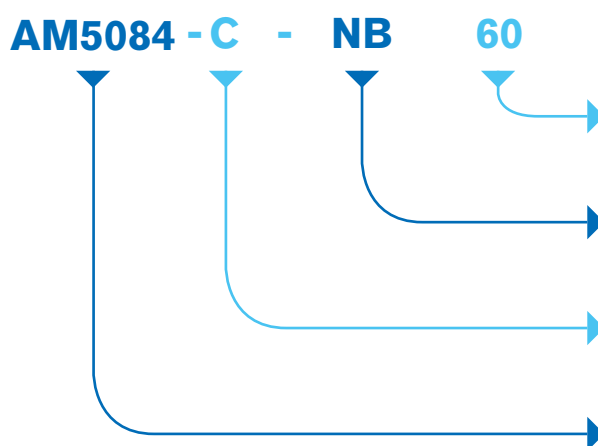

HARDNESS
SHORE A

MATERIAL FAMILY DESIGNATORS
NBR - NITRITE

METAL RING
C-CAST IRON

SIZE REFERENCE



For further details

<http://www.pioneerweston.com>

Weston Mechanical Seals

If speed, pressure and the working environment are above the norm then a Weston bespoke sealing arrangement could be the solution.

Features

- Extremely flat precision lapped faces pressed together creating a primary seal. One rotating with the shaft and one stationary within a housing
- Secondary seal (elastomeric compound or gasket material)
- Mechanical loading device (e.g. spring)
- Balanced and unbalanced options

Benefits

- Contamination exclusion and media retention is achieved via precision lapped faces
- Maximum seal life is achieved by the balanced sealing arrangements controlling closing force, reducing wear and temperature
- Improved shock load resistance from balanced seal arrangements preventing separation of mating faces
- Face arrangements can cope better than Labyrinth type arrangements with higher pressures and more aggressive environments
- Weston Mechanical Seals can be fully submerged without leakage

Applications

- Industrial gearboxes



Common face combinations are as follows:

Material Combinations	Select for...
Phosphor Bronze Vs Stellite®	Good for grease/oil applications on large diameters
Stellite® face Vs Carbon	Good in aqueous solutions
Carbon Vs Hardened Steel	General and cost effective combination, not suitable for water sealing applications
Silicon Carbide Vs Silicon Carbide	Special arrangements at higher speeds / pressures and more aggressive environments
Phosphor Bronze Vs Steel	Used for large diameter applications

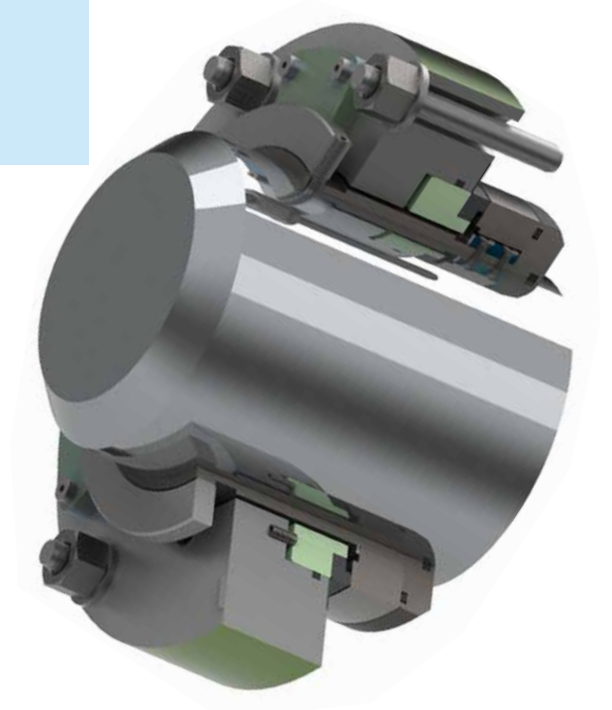

Balanced Mechanical Seal

Type CBAF

This seal design includes a flange as an integral part of the seal body which positions and provides the means of bolting the assembly to a faced housing.

The bolt sizes, PCD's and flange dimensions can all be varied to suit customer requirements making the seal truly versatile.

The seal unit is stationary and mates with a rotary seal face mounted on the shaft.

Features	Benefits
Short axial length	Reduces bearing overhang
Multiple compression springs	Ensures even face load distribution
Balanced	Accommodates high pressure
Variable seal face materials	Lesser lubricated regimes possible
Fully contained assembly	Easily fitted, no loose parts
Spigot	Location fit ensures concentricity
Flange gasket	Ensures leak free joint
Flange	Accurately positions seal
Alternative elastomers / metals	Full range of environments

Standard Materials	
Primary seal	Resin filled carbon
Secondary seal (O-ring)	Fluoroelastomer
Retaining ring	Springsteel
Compression springs	Stainless steel
Other metal parts	Mild steel
Flange gasket	Asbestos free gasket

Maximum Working Conditions	
Sliding speed	45 m/s
Pressure	25 bar
Temperature	160°C
PV value	400 bar/m/sec

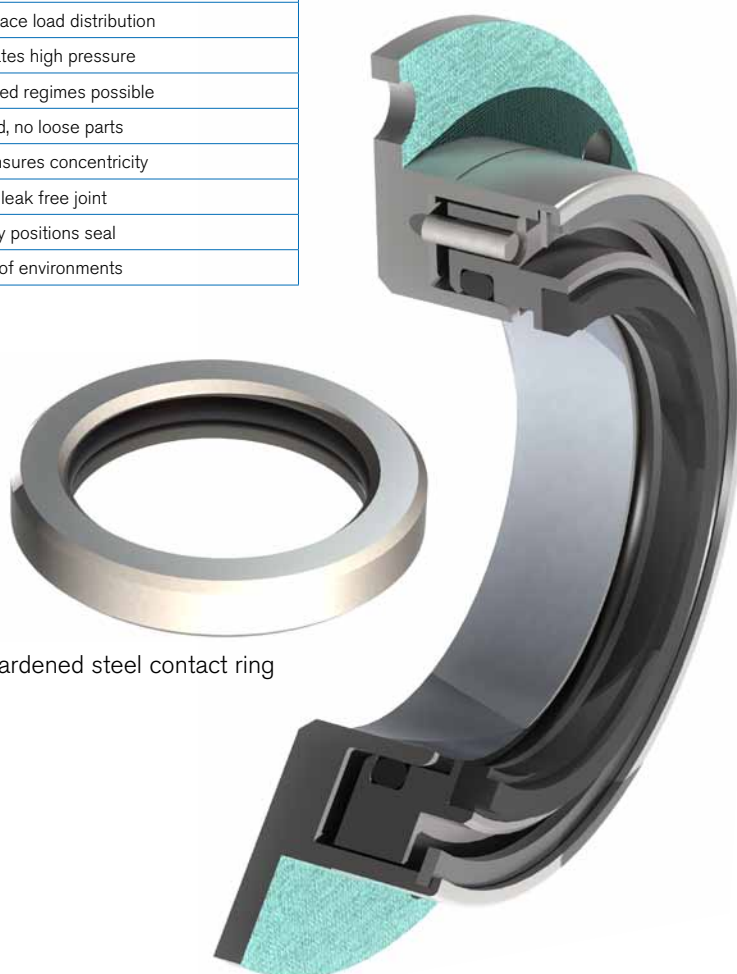

Also available in non-flanged configurations

Non-Balanced Mechanical Seal

Type MRX

This seal design includes a flange as an integral part of the seal body which positions and provides the means of bolting the assembly to a faced housing. The dynamic sealing surface can mate directly to hardened faces on the customer's hardware or a Pioneer Weston supplied contact ring.

The bolt sizes, PCD's and flange dimensions can all be varied to suit customer requirements making the seal truly versatile.

The seal is non-balanced, suitable only for low pressure use and is fitted with a diaphragm which acts essentially as a static seal.

The diaphragm excludes sludge and slurry from the sealing mechanism that could cause "hang up".

The seal unit is stationary and mates with a rotary seal face, mounted on the shaft.

Features	Benefits
Short axial length	Reduces bearing overhang
Multiple compression springs	Ensures even face load distribution
Diaphragm	Prevents clogging
Fully contained assembly	Easily fitted, no loose parts
Spigot	Location fit ensures concentricity
Flexibly mounted seal face	Copes with increased misalignment

Standard Materials	
Primary seal	Phosphor bronze
Diaphragm	Fibre reinforced elastomer
Seal body	Aluminium alloy
Compression springs	Stainless steel
Driving pins	Stainless steel
Flange gasket	Asbestos free gasket

Maximum Working Conditions	
Sliding speed	45 m/s
Pressure	0.30 bar
Temperature	150°C
PV value	15 bar/m/sec

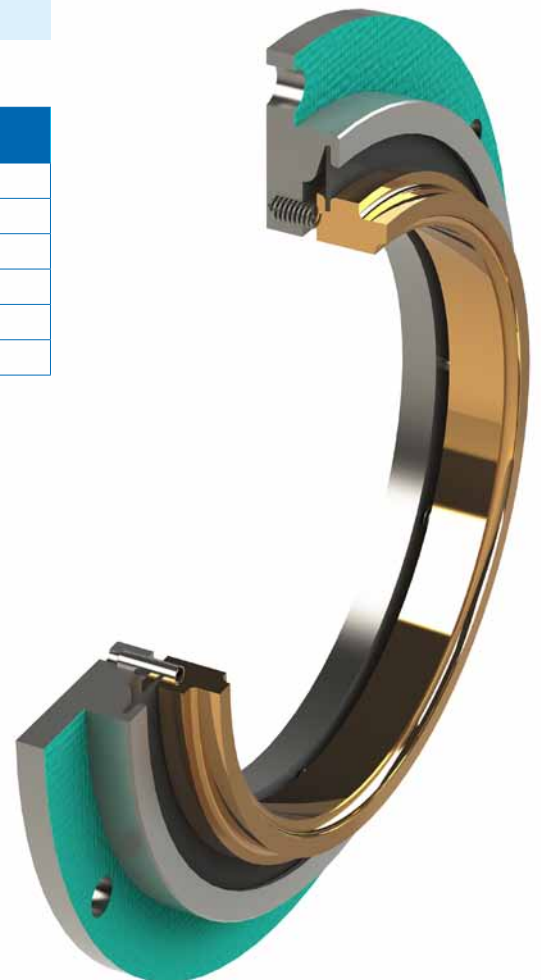

Non-Balanced Mechanical Seal

Type MRZ

The MRZ seal design is very compact and suitable for use where a good supply of lubrication is available to the seal face. The dynamic sealing surface can mate directly to hardened faces on the customer's hardware or a Pioneer Weston supplied contact ring.

The seal, unlike the MRX style, has no location spigot or flange but is located by means of a press fit on the O.D.

The seal is non-balanced, suitable only for low pressure use and is fitted with a diaphragm which acts as a static seal.

The diaphragm excludes sludge and slurry from the sealing mechanism that could cause "hang up".

The seal unit is stationary and mates with a rotary seal face, mounted on the shaft.

Features	Benefits
Short axial length	Reduces bearing overhang
Multiple compression springs	Ensures even face load distribution
Diaphragm	Prevents clogging
Fully contained assembly	Easily fitted, no loose parts
Interference O.D. fit	Leak free joint
Flexibly mounted seal face	Copes with increased misalignment

Standard Materials	
Primary seal	Phosphor bronze
Diaphragm	Fabric reinforced elastomer
Seal body	Aluminium alloy
Compression springs	Stainless steel
Driving pins	Stainless steel

Maximum Working Conditions	
Sliding speed	45 m/s
Pressure	0.30 bar
Temperature	150°C
PV value	15 bar/m/sec

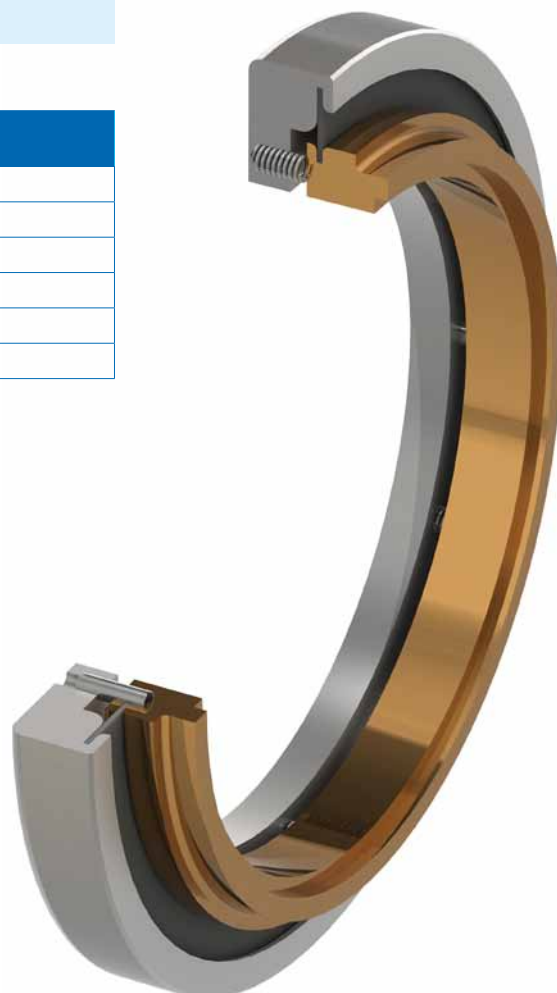

Face Type Seal

Type FTS

Most FTS designs tend to be employed in the steel industry for shaft sizes ranging from 100mm to 1000mm where they are fitted to roll necks on tube mills and continuous casters, protecting the roll bearings from the ingress of hot iron scales and water.

Features

FTS designs comprise an un-balanced sealing arrangement where the dynamic sealing member is energised by pocket springs, assisted by the differential pressure of the lubricating media (typically grease). All designs feature flange location. The dynamic sealing surface mates to a Pioneer Weston supplied contact ring.

Benefits

Positive containment of grease.

Materials

Phosphor bronze v's Stellite® faced steel

Face type seal with phosphor bronze sealing member against a Stellite® faced contact ring



Vulc-O-ring

Product overview

ERIKS has developed a very successful method of producing O-rings from extruded cord to a very high technical standard.

The main benefits of Vulc-O-rings are:

- Moulds are not required resulting in cost savings
- No upper diameter restrictions such as moulding
- No flash lines are present
- Can be used in standard housings
- Short lead times



Metric Vulc-O-rings

1999.35 x 5.7 FPM 75 514206 - VULC

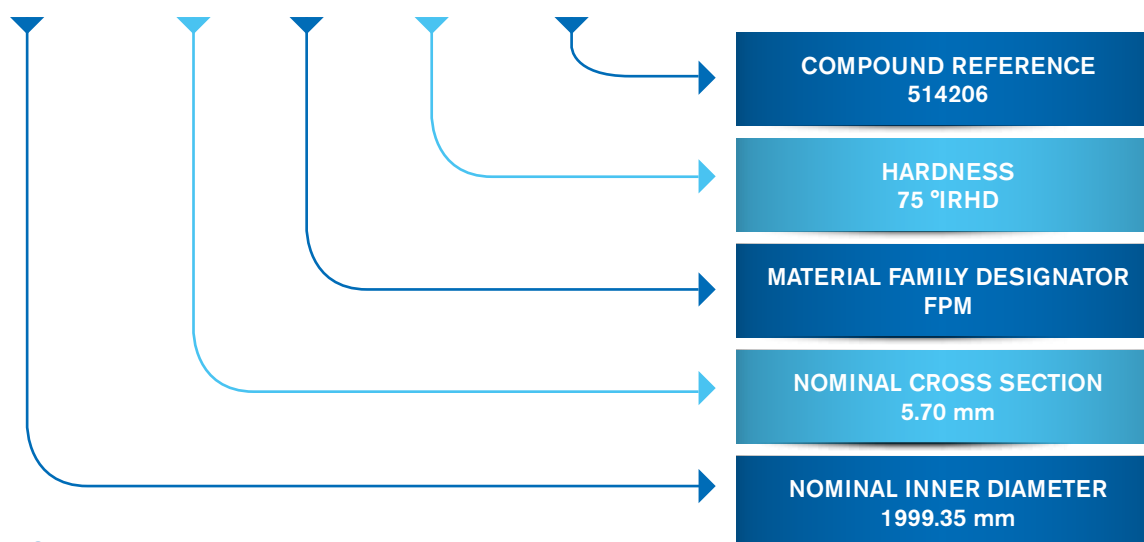

Vulc-O-ring Materials

Elastomer	Material Family Designator	Compound Reference	Colour	Hardness °IRHD
Nitrile (NBR)	NBR	366185	Black	75
Fluorocarbon (FKM) A Type	FPM	514206	Black	75
Fluorocarbon (FKM) GF Type	FPM	514141	Black	75
Silicone (VMQ)	SIL	714206	Red	75
Ethylene Propylene Diene Monomer	EPDM	559303	Black	75

Spring Energised Seal

Product overview

The Spring Energised (SE) seal pressure activated seal, with assisted energisation provided by corrosion-resistant metal spring. When the seal is in situ, the spring is under compression and applies force to seal's sealing lips. This creates a tight barrier to the seal to prevent gas or fluids from leaking.

The spring also provides resiliency to compensate for seal wear, gland misalignment or eccentricity. While spring force provides adequate force for sealing at low pressure, at high pressure the system pressure augments the spring force to provide an even tighter seal. SE seals are precision machined from PTFE, filled PTFE and other high performance polymers. SE seals work consistently under a wide array of temperatures and pressures. ERIKS offers over 100 jacket materials, 8 spring materials, and 5 spring designs to meet your sealing needs.

Spring Designation

Spring Type	Material Code	Material Description
Cantilever	1	301 Stainless Steel
	6	316 Stainless Steel
	H	Hastelloy® C-276
	E	Elgiloy®
Spiral Pitch	2	302 Stainless Steel
	6	316 Stainless Steel
	H	Hastelloy® C-276
Helical	2	302 Stainless Steel
	H	Hastelloy® C-276

PTFE Grades

Material Reference	Description	Wear Factor (K)	Application
E431	Glass and Molybdenum Disulphide reinforced PTFE	15	Dynamic / Static, Medium duty cycles Hardened metal running surfaces
E471	Graphite reinforced PTFE	10	Dynamic, Medium duty cycles
E462	Carbon/Graphite reinforced PTFE	15	Dynamic, Medium duty cycles
E491	Polyester reinforced PTFE	2	Dynamic / Static, Medium to high duty cycles, Minimum 45 HRc running surface
E282Z	Carbon/Graphite/PPS reinforced PTFE	1	Dynamic / Static, High duty cycles, Hardened metal running surfaces

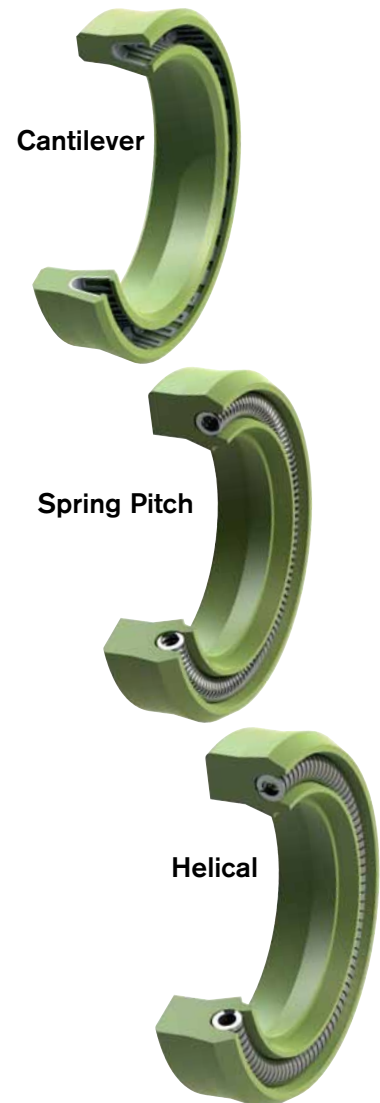

E - V - 1 - A - 1 - M - 136 - E431

MATERIAL CODE
E431

DASH SIZE REFERENCE
136

SPRING LOAD
L – Light
M – Medium
H – Hard

SPRING MATERIAL
301 Stainless Steel

LIP CONFIGURATION
ROD AND PISTON SEALS:
A – Standard
B – I.D. Scraper
C – O.D. Scraper
D – Double Scraper
FACE SEALS:
A – Standard

SEAL TYPE
ROD AND PISTON SEALS:
1 – Standard heel rod seal
2 – Standard heel piston seal
3 – Extended heel rod seal
4 – Extended heel piston seal
FACE SEALS:
5 – Internal face seal
6 – External face seal

SPRING TYPE
V – Cantilever
S – Spiral pitch
H – Helical

PRODUCT LINE
E

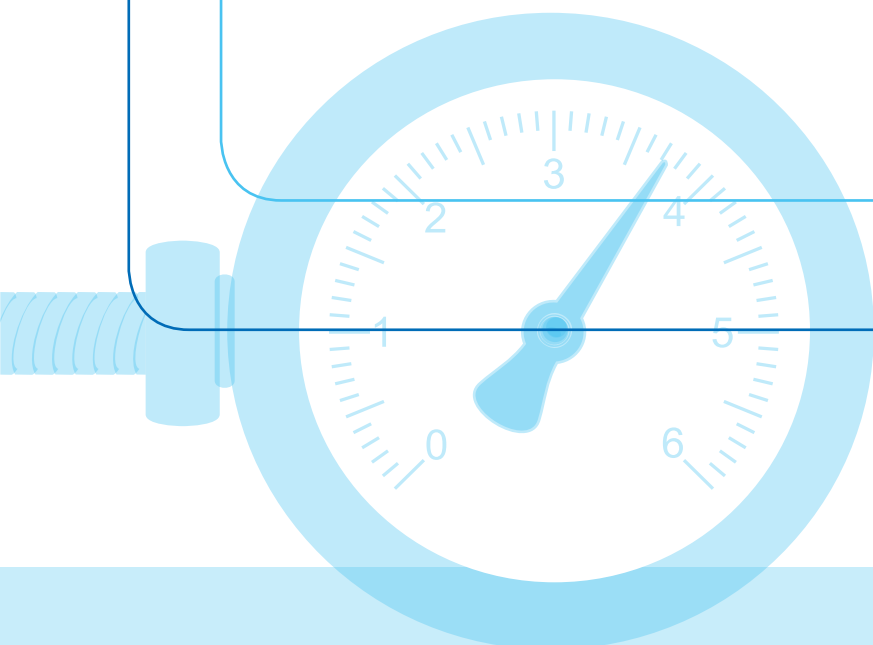

O-ring

Product Overview

The most common type of static seal is the flexible elastomer O-ring. O-rings provide an affordable seal that in most cases are simple to install and subject to correct material selection, give acceptable life between maintenance checks.

Available in a variety of materials to suit every sealing application, fully moulded O-rings are manufactured to several international sizes standards, including BS1806, BS4518, AS568 and ISO 3601. Alternatively non-standard custom sizes, up to 2.5m (8ft) diameter can be produced to specific requirements.



O-ring Standard Compounds

Elastomer	Colour	Hardness (IRHD)	Temperature Range	Select for..	Compound Reference	Material Family Designator
Nitrile rubber (NBR)	Black	70	-30 to +120°C	Standard compound with good compression set values. Medium acrylonitrile content for use with hydraulic oils, alcohols, water, air, fuels and many other fluids.	36624	NBR
Fluorocarbon (FKM, A-type)	Black	75	-20 to +200°C	General purpose compound with very low compression set characteristics at high temperatures. Chemically resistant to oils, greases and fuels.	51414	FPM
Silicone (VMQ)	Red	70	-60 to +220°C	High and very low temperature	714177	SIL
Polychloroprene (CR, Neoprene)	Black	70	-35 to +110°C	Good ageing characteristics in ozone and weather environments, along with abrasion and flex-cracking resistance. Offers resistance to fluorine-based refrigerants.	32906	CR
Polyurethane (AU)	Black	70	-40 to +95°C	Standard compound offering excellent performance in dynamic applications due to the materials inherent excellent wear resistance.	900270	AU
Hydrogenated nitrile (HNBR)	Black	70	-30 to +180°C	General purpose compound offering improved temperature resistance over NBR grades. Good oil, coolant and hydrocarbon resistance, with excellent abrasion resistance.	88625	HNBR

Imperial O-rings

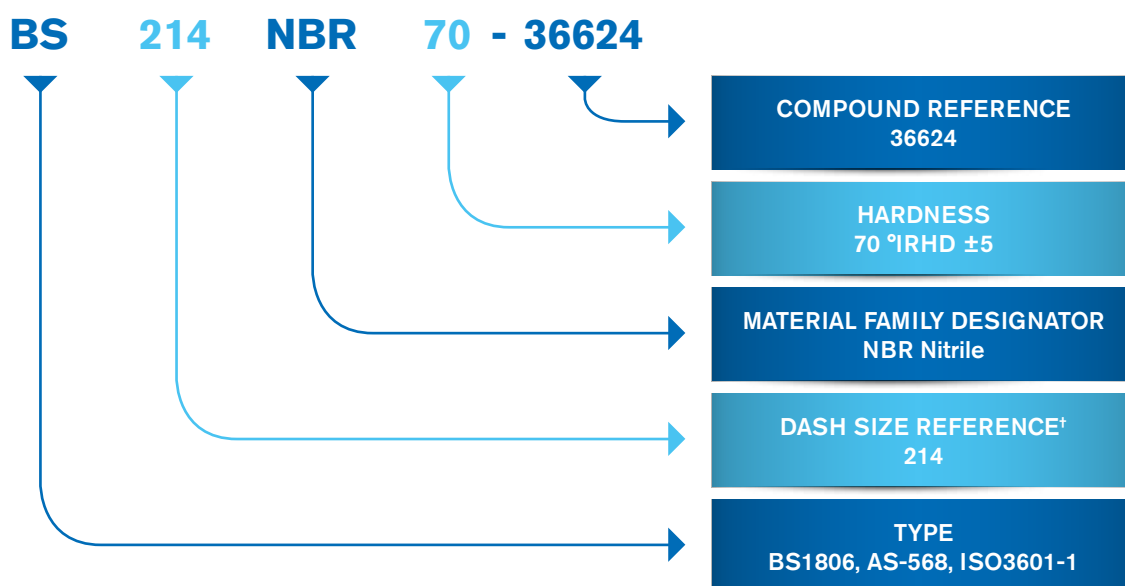

†O-rings are supplied to ISO3601-1 class 2 tolerances unless otherwise specified.

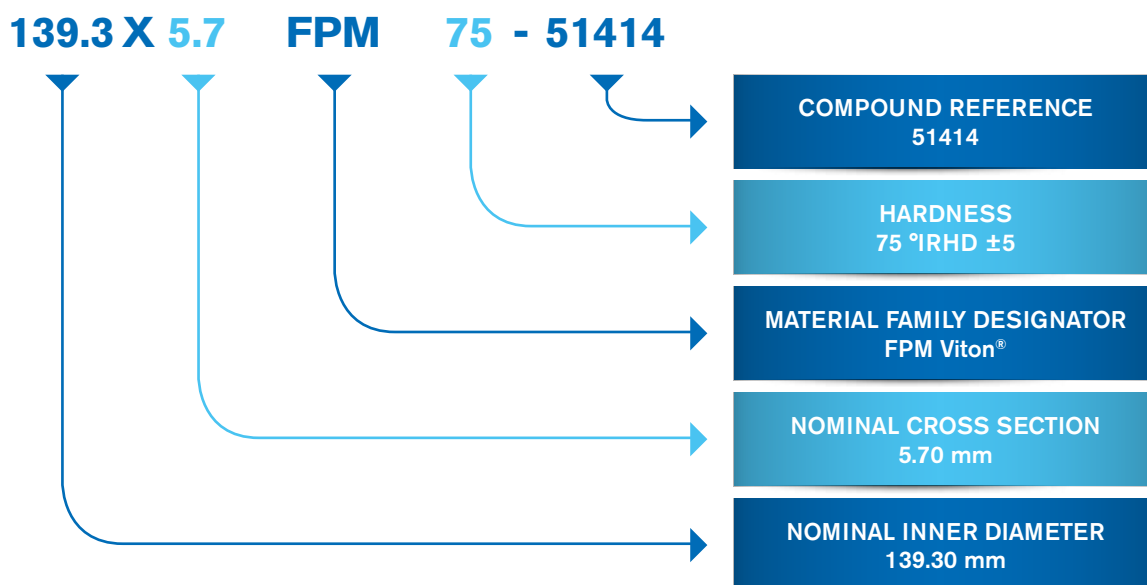

Metric O-rings



†O-rings are supplied to ISO3601-1 class 2 tolerances unless otherwise specified.

Heavy Duty Hydraulic Seal Profiles

Wear rings / Bearing strip

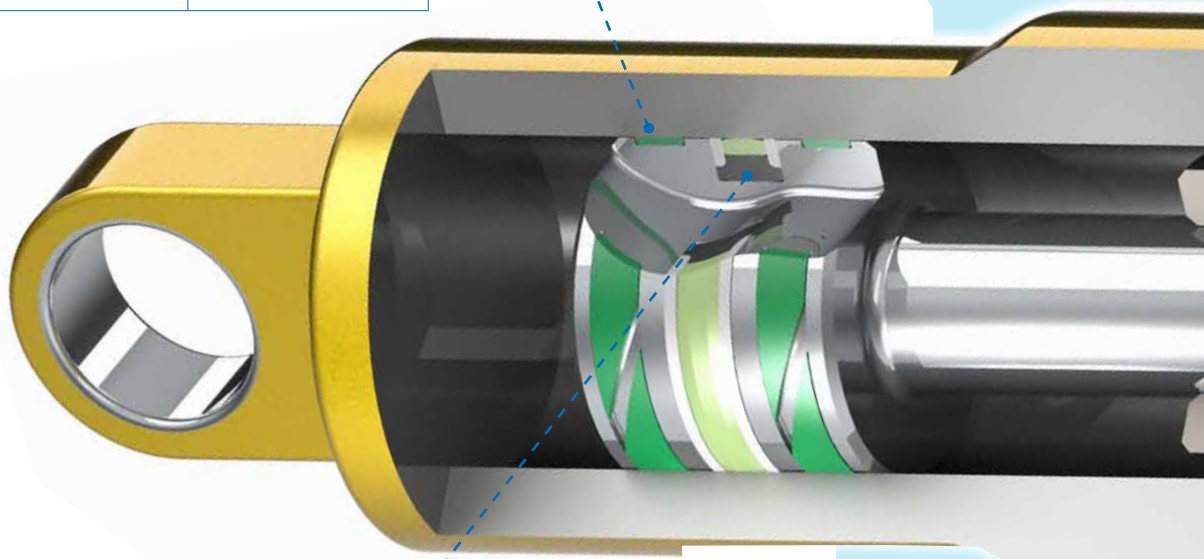

	Features	Advantages
Fabric Reinforced 	<ul style="list-style-type: none"> - High compressive strength - High compressive modulus - High pressure velocity rating (PV) factor - Low wear rate 	<ul style="list-style-type: none"> - High side load - Outstanding alignment - Low axial length requirement - Long life
PTFE Styles 	<ul style="list-style-type: none"> - Low friction - Self lubricating - Low wear 	<ul style="list-style-type: none"> - Energy efficient - Dry running possible - Long life



Piston seals

	Features	Advantages
DOP 	<ul style="list-style-type: none"> - Elastomeric energiser - Compliant, wear resistant sealing element - High strength anti-extrusion rings 	<ul style="list-style-type: none"> - Low compression set for extended operating life - High sealing efficiency - High pressure operation with large diametral clearances
DWO 	<ul style="list-style-type: none"> - Elastomeric energiser - Compliant, wear resistant sealing element - High strength anti-extrusion rings - Integral bearing features 	<ul style="list-style-type: none"> - Low compression set for extended operating life - High sealing efficiency - High pressure operation with large diametral clearances - Reduced axial length requirements

Rod Seals

	Features	Advantages
UR 	<ul style="list-style-type: none"> - Pressure activated - Axially located within groove - Rectangular heal - Cantilever sealing lip 	<ul style="list-style-type: none"> - Efficient sealing efficiency - Low hysteresis - Rotation prevention - Low friction
ELS 	<ul style="list-style-type: none"> - Pressure activated - Axially located within groove - Rectangular heal - Cantilever sealing lip - Positive energisation by low modulus material - Wear resistant, high modulus jacket 	<ul style="list-style-type: none"> - Efficient sealing efficiency - Low hysteresis - Rotation prevention - Low friction - Low pressure sealing - Long life and high pressure operation

Wipers / Scrapers

	Features	Advantages
WSF 	<ul style="list-style-type: none"> - Pressure activated - Axially located within groove - Combined scraping and sealing - Cantilever sealing lip 	<ul style="list-style-type: none"> - Efficient sealing efficiency - Low hysteresis - Low axial length requirement, ideal for secondary sealing - Low friction
WSB 	<ul style="list-style-type: none"> - Metallic insert location - Extended scraping lip 	<ul style="list-style-type: none"> - Press-fit - Excellent contaminant exclusion



*O-ring and hardware dimensional details are available at:
<http://oring-groove-wizard.eriks.co.uk/diametergrooves.aspx>

V-rings

V-rings are an elastomer axial seal for shafts and bearings, installed onto the shaft or counterface. This type of seal has been used widely for many applications and has proved to be reliable and effective against dust, dirt, water, oil splash and other media.

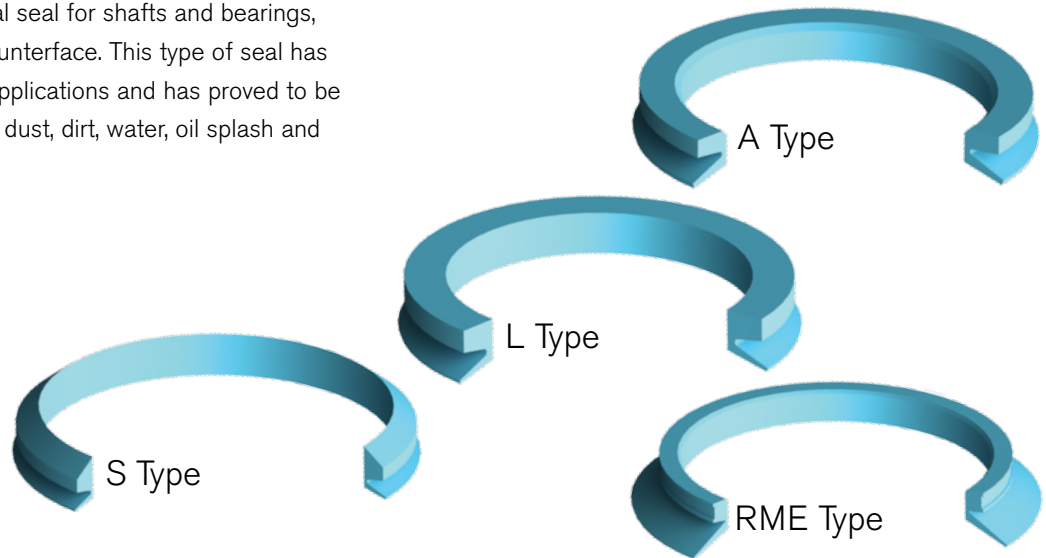

Carbon Segment Seals

Typically used in series for high speed rotary applications. Carbon segment seals are energised by a garter spring and act as a leakage control device, allowing the generation of differential pressures. Typical uses would include staged rotary compressors and turbines.



Lip Seals for use in Autoclaves

Pipeline closures offer a unique set of challenges to seals making very specific sealing solutions necessary:

Application conditions:

- 50, 300, 600, 900, 1200, 1500 ASA pressure ratings
- Wide operating temperature ranges starting from -46°C
- Diverse fluid media
- Over-compression of the seal during door closure
- Very high clearance gaps
- Low closure force requirements
- Low pressure sealing requirements
- Fast activation required to accommodate pressure fluctuations
- Pressure trapping in groove
- Large diameters
- Uneven clearance gaps due to effects of gravity on heavy horizontally opening doors
- Rapid Gas Decompression resistance

Specially designed lip seals with or without reinforcing elements may be used to meet this challenging combination of application requirements. Careful design optimisation using Finite Element Analysis is often critical to success.

Laminar Seals

Laminar seals are a labyrinth arrangement of metallic rings that when installed in series form a passive non-contact seal that meters the flow of grease under a positive pressure. Sequential rings interfere on the inner and outer diameters and are available as single or multi-wind versions.

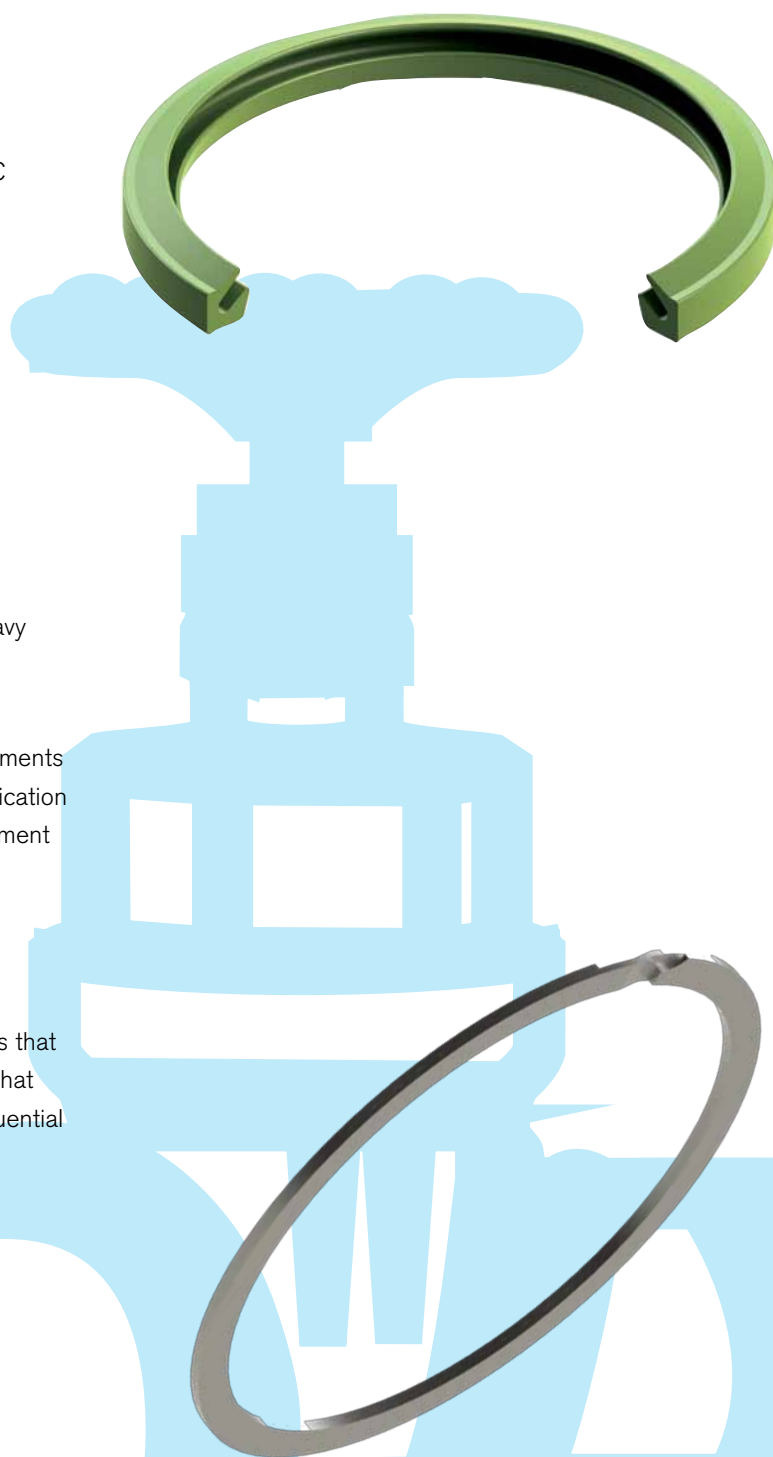

Component Mechanical Seals

Bellow Seals

Bi-directional and extremely versatile, these bellow seals are designed with no loose parts that could be damaged during installation, and feature static sealing that cannot cause shaft wear or fretting. Suitable for a wide range of applications, such as pumps, mixers, agitators and compressors, they can also be used where a previous seal has caused shaft damage.

- Wide range of metric and imperial sizes
- For shafts from 8mm to 100mm
- Faces: carbon, ceramic and silicon carbide



Stationary Components

Generally O-ring mounted stationary components, or seats, are available in various materials to suit application requirements.

- Some designs feature a pin groove, providing positive drive to the seal face. It is important to consider the application conditions and condition of the equipment when selecting a stationary component
- The stationary component illustrated represents those commonly found in use today



Taper Spring Seals

An extremely popular and effective design featuring positive uni-directional drive via the spring, these seals are available in a wide range of sizes and styles, and are used in many applications, including pumps, mixers, agitators and compressors.

All designs feature O-ring sealing on the shaft and positive spring drive.

- Wide range of metric sizes
- For shafts from 10mm to 100mm
- Faces: carbon, ceramic, stainless steel and silicon carbide



Parallel Spring Seals

Widely used as the standard upgrade from packing to mechanical seals, parallel spring seals are the mainstay for many industries. Using a rubber bellows to seal against the shaft and provide drive to the face, they are suitable for use in applications such as water, food and chemical processing. Designs are also available with a balanced configuration to reduce heat and friction, extending seal life.

- Wide range of metric and imperial sizes
- For shafts from 10mm to 75mm
- Faces: carbon, ceramic and silicon carbide



Other Brochures in this Series

Chemical Process Industry

Oil and Gas Applications

Agriculture and Earth Moving Applications

Automotive and Transport Applications

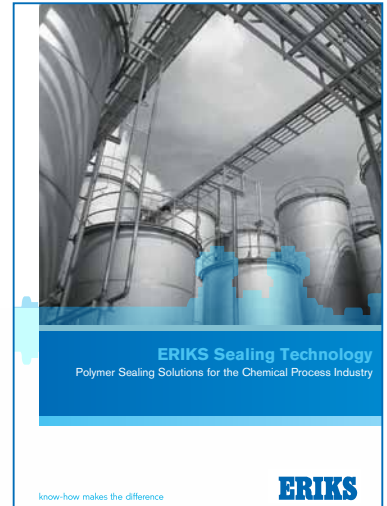

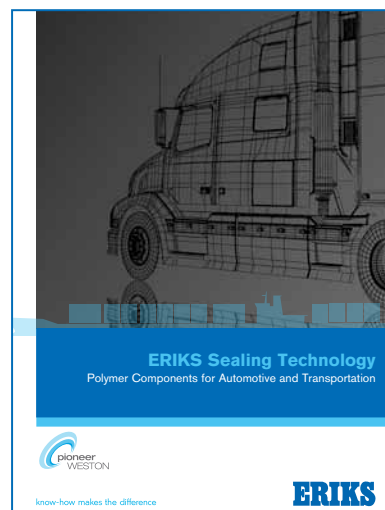
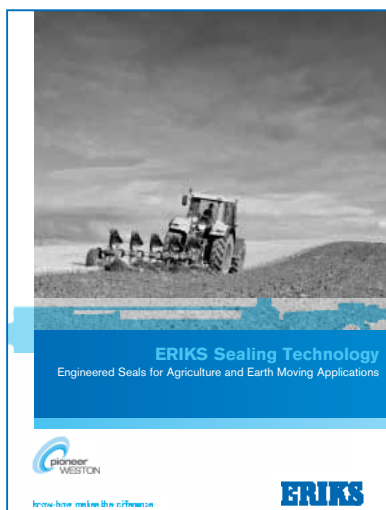

Kitting and Bagging

ERIKS Sealing Technology can provide bespoke kits and aftermarket bagging of individual parts to service your industry requirements.

Our specially tailored kits are assembled and packaged with clearly marked part numbering and can be supplied with our own brand, or alternatively, customer specific branding.

We are able to offer kits that include a variety of our core product, ranging from Rotary Seals and O-rings to Hydraulic Seals, Washers and Gaskets.



ERIKS Sealing Technology

ERIKS Sealing Technology offers a comprehensive range of high performance sealing products, supported by a world-class technical and logistical service to deliver the right seal on time to your critical applications.



ERIKS Sealing Technology

**Unit 5, Yorks Park
Blowers Green Road
Dudley
West Midlands
DY2 8UL**

Tel 0845 603 1221

Fax 0845 603 1441

www.eriks.co.uk

ERIKS Sealing Technology

**206 Cavendish Place
Birchwood Park
Warrington
Cheshire
WA3 6WU**

Tel 01925 853000

Fax 01925 853030



know-how makes the difference

ERIKS